



Technical guide for furnishing & design

1620x3240

12+ | 20+

06.2021 - EN

Technical guide for furnishing & design

1620x3240

12+ | 20+

06.2021 - EN

Index



Introduction	4
1 Technical information	5
1.1 One surface, a multitude of technical features	6
Technical specifications - furniture industry	8
2 Packaging and packaging materials	13
3 Handling and storage	16
3.1 Moving A-Frames with a lift truck (forklift)	16
3.1.1 Loading/Unloading A-Frames on/from Lorries	17
3.1.2 Loading/Unloading A-Frames into/from Containers	18
3.2 Handling and Loading/Unloading Big A-Frames	19
3.3 Handling a single slab	21
3.4 Storing the Slabs	22
4 Quality Control on Laminam 12+ and Laminam 20+	24
4.1 Dimensions	24
4.2 Thickness	25
4.3 Planarity	25
4.4 Shade	27
4.5 Surface Quality	27
4.6 Variations in graphics on materials	28
4.7 Labelling and marking	28
5 Guidelines for designing top surfaces and furnishing complements with Laminam 12+ and Laminam 20+ slabs	29
5.1 Minimum distances from the edges	29
5.2 Internal Angles	29
5.3 Designing holes for sinks and hobs	30
5.3.1 Overtop Installation	32
5.3.2 Flush Installation	32
5.3.3 Undertop Installations	33
5.3.4 Installation with 45° fitting	33
5.4 Creation of lowered areas in the countertop to place the sink	34
5.5 Creating a dripstone on Laminam countertops	35
5.6 Sinks Made in Laminam Ceramic	36
5.6.2 Making a sink with a tilted integrated drip catcher	38
5.6.3 Making a sink without a base pan	39
5.6.4 Making a sink with a base pan	39
5.6.5 Undertop integration of Laminam sink	39
5.6.6 Integration of Laminam sink at 45° with the countertop	40
5.6.7 Anchoring and handling of integrated sinks	40
5.7 Verifying the base units and supports for the countertop	41
5.7.1 Kitchen and bathroom countertops	41
5.8 Creating protruding parts and overhangs with Laminam 12+ and 20+	42
5.9 Tables	43
5.10 Top joints and extensions	44

6	Laminam processing	46
6.1	Processing Laminam 12+ and Laminam 20+ slabs	46
6.1.1	Orientation of slabs during processing	47
6.1.2	End of processing	48
6.2	Disc cutting	48
6.2.1	Cutting Scheme	48
6.2.2	Indications	50
6.2.3	Parameters	52
6.3	Water-jet Processing	52
6.3.1	Cutting Scheme	53
6.3.2	Parameters	55
6.4	Numerical Control Processing	56
6.4.1	Positioning Suction Pads	57
6.4.2	Flush Top Processing	58
6.4.3	Flush Top Processing	59
6.4.5	Cutting Parameters	60
6.6	Manual Processing	61
6.7	Cleaning after processing	62
7	Edges	63
7.1	Straight Edges and Bevels	63
7.2	Other types of edges	64
7.3	Edges and Box Structures	64
7.4	IN-SIDE Edge Finish	66
7.5	Fibre Abrasion	66
8	Bonding laminam on other materials	67
9	Transport and installation of the finished countertop	68
9.1	Packaging and transport	68
9.2	Installation	69
9.3	Cleaning after installation	71
10	Cleaning, use and maintenance	72
11	Safety information	74
12	Liability disclaimer	75
13	References	76
	Certifications	90

I ntroduction



Every Laminam XL ceramic slab is meticulously manufactured using the most innovative technology available to the ceramic industry. This production line is carefully constructed to deliver precious millimeters of additional usable surface area, allowing savvy manufacturers to expand their design freedom. Available in the size 1620x3240 and thickness of 12,5 mm and 20,5 mm.

Laminam surfaces are designed to be used as horizontal furniture surfaces such as table-tops, bathroom and kitchen countertops. Ceramic slabs constitute an alternative to materials like marble and stone, which have higher costs and ecological impacts.

Due to their excellent technical performance levels, Laminam slabs are ideal for more delicate uses which require maximum levels of hygiene and resistance. The aesthetic qualities and large slab size provide authentic artistic benefits while guaranteeing continuity of the material throughout the room. Each slab is designed with natural and vibrant colors.



1 | Technical information



Distinctive Values of Laminam 12+ e Laminam 20+

Laminam 12+ and Laminam 20+ are slabs in porcelain stoneware in the respective thicknesses of 12,5 mm and 20,5 mm full-body in XL size 1620x3240 mm.

Laminam 12+ consists of the basic slab reinforced structurally with a fiberglass mesh glued to the back with a specific adhesive. Its nominal thickness is 12,5 mm (0.49")

Laminam 20+ consists of the basic slab reinforced structurally with a fiberglass mesh glued to the back with a specific adhesive. Its nominal thickness is 20,5 mm (0.80").

Use of Laminam 12+ e Laminam 20+

- > Bathroom and interior design sector: surfaces for bathrooms and kitchens, tables, furnishing complements.
- > Construction sector: ventilated facades, raised floors and high traffic walkways, claddings
- > Shipbuilding sector: finishing material.

Technical specifications for Laminam 12+ e Laminam 20+

Porcelain stoneware obtained by wet-grinding clay, granite and metamorphic rock raw materials together with a feldspar component and ceramic pigments.

Specially shaped in a compactor and sintered at 1200°C, with hybrid gas and electrical firing. Structurally reinforced with a fiberglass mesh bonded on the back.

1.1 One surface, a multitude of technical features*



Easy to clean and maintain

Laminam is simple, fast and easy to clean. Laminam has no special maintenance requirements as time goes by; generally speaking, all you need to clean the surface is warm water and a neutral detergent.



Hygienic surface

Laminam surfaces are ideal for application in places where maximum hygiene is needed.



Suitable for contact with foodstuffs

Laboratory tests have proven that Laminam is totally compatible with foodstuffs.



Resistant to mould and fungi

Laminam does not allow mould, bacteria or fungi to grow.



Impervious surface

Laminam surface porosity is average 0,1%.



Resistant to freeze-thaw

Laminam is frost resistant and suitable for any weather condition, thanks to its low average water absorption (0,1%).



Dimensional stability

Laminam is not subject to dimensional variations of any significance, as it has a low coefficient of thermal expansion.



Suitable for indoor and outdoor applications

Laminam can be used both for interior and exterior décor. Weathering exposure does not damage or alter surfaces.



Resistant to heat and high temperatures

The ceramic surface does not contain any organic materials and so its surface is not altered in case of direct contact with very hot items in the kitchen, like pots and pans, and high temperatures, without any alterations.



Resistant to staining**

Laminam is not affected by prolonged contact with products commonly found in the kitchen that can cause staining, such as wine, coffee, olive oil or lemon juice, and its colour or shine will not be affected permanently.



Resistant to detergents and cleaning products***

Laminam resiste al contatto prolungato con i detersivi reperibili in commercio per la pulizia della casa, inclusi sgrassatori e anticalcare. Si pulisce con estrema facilità mantenendo inalterate le caratteristiche della superficie.



Resistant to chemicals, acids, alkalis and solvents***

Laminam is not affected by organic and inorganic solvents, chemical and disinfectants. The only chemical that can damage ceramics is hydrofluoric acid.



Resistant to thermal shock

Laminam slabs are resistant to thermal shock in both indoor and outdoor environments.



Resistant to humidity

The ceramic surface of Laminam is not affected by long-term humidity exposure.



Resistant to UV rays, no alteration to colours

Laminam surface is not affected by exposure to UV light and will preserve its original good looks throughout its lifetime.



Resistant to deflection

Laminam has a high modulus of rupture.



Resistant to scratches and abrasions****

Laminam is resistant to scratching and deep abrasion. Its properties do not change even if it is subjected to intensive use and frequent cleaning.



Eco-friendly and recyclable

Laminam is a product made of 100% natural materials. It does not release any elements into the environment and can be easily milled and recycled in other manufacturing processes.



IN-SIDE plus

The IN-SIDE technology combines advanced technical performance in terms of resistance and durability of Laminam surfaces with aesthetic qualities that further respond to the requirements of the furnishing and architectural industries. Body and surface continuity even after cutting, drilling, edging *****

* For the surface properties of the individual finishes, see technical data sheets at the end of the catalogue

** On Lucidato surfaces, stubborn stains must be removed quickly

*** On Lucidato surfaces, very aggressive detergents (such as bleach) must be removed quickly

**** Laminam slabs with Lucidato finishes, are resistant to deep abrasion, but less resistant to superficial scratches. However, Lucidato surfaces still offer a similar or a better performance than other natural and artificial materials used to make horizontal furnishing surfaces.

***** Valid for IN-SIDE technology

Technical specifications - furniture industry



physical and chemical properties	norm-test method	Laminam 12+	Laminam 12+ Lucidato
density	EN 14617-1 ASTM C97	2500 kg/m ³ (average value)	2500 kg/m ³ (average value)
water absorption	EN 14617-1	average value ≤ 0,1% *	average value ≤ 0,1% *
bending strength	EN 14617-2	50 MPa (average value)	50 MPa (average value)
freeze and thaw resistance	EN 14617-5	resistant	resistant
dry heat resistance	EN 12722 EN 438-2 par.16	5 (no visible effect till 200°C)	5 (no visible effect till 200°C)
chemical resistance	ISO 10545-13	from class A to B	from class A to C
chemical resistance	ASTM C650	resistant	resistant (except potassium hydroxide)
cold liquid resistance	EN 12720	5 no visible effect except ink (2)	from class 5 to 2
cleaner product resistance	PTP 53 CATAS	5 no visible effect	from class 5 to 3
abrasion resistance	EN 14617-4	28,0 mm	28,0 mm
hygiene properties	Metodo CATAS	excellent (high degree of removal of bacterial cells >99% after cleaning with a biocide-free detergent)	excellent (high degree of removal of bacterial cells >99% after cleaning with a biocide-free detergent)
resistance to fungi	ASTM G21	no fungal growth	no fungal growth
lead and cadmium given off	ISO 10545-15	0 mg/dm ³	0 mg/dm ³
overall migration	UNI EN 1186	0 mg/dm ² no significant migration	0 mg/dm ² no significant migration
VOC emission	UNI EN 16000-9	class A+ french	class A+ french
shock resistance	ISO 4211-4 EN 14617-9	no damage to ball drop 400mm average value 3 J	no damage to ball drop 400mm average value 3 J
light resistance	UNI EN 15187	5 no visible effect	5 no visible effect
thermal shock resistance	EN 14617-6	resistant	resistant
resistance to staining	ASTM C1378	resistant	resistant (except ink and methylene blue)

* Value relative to the ceramic body only

The unique features of Laminam products do not allow for a perfect comparison with ceramic tiles. The test results are therefore only indicative and not binding.

Technical specifications - furniture industry



physical and chemical properties	norm-test method	1620x3240 Full Size Laminam 12+	1620x3240 Full Size Laminam 12+ Lucidato
Full Size: "length and width" nominal size: 1620x3240mm size / (63.7"x 127.5")	Laminam	minimum size: ≥ 1630x3250mm full size untrimmed	minimum size: ≥ 1630x3250mm full size untrimmed
weight	Laminam	average value 30 kg/m ²	average value 30 kg/m ²
surface quality / % pieces with no visible flaws	ISO 10545-2	> 95%	> 95%
water absorption	ISO 10545-3 / ASTM C373	average value ≤ 0,1% *	average value ≤ 0,1% *
breaking strength in N	ISO 10545-4	> 4000 * (sample dimensions 400x800 mm)	> 4000 * (sample dimensions 400x800 mm)
modulus of rupture in N / mm ²	ISO 10545-4	average value 50 * (sample dimensions 400x800 mm)	average value 50 * (sample dimensions 400x800 mm)
resistance to deep abrasion	ISO 10545-6	≤ 175 mm ³	≤ 175 mm ³
coefficient of linear thermal expansion / 10 ⁻⁶ /°C	ISO 10545-8	6,6 average value *	6,6 average value *
resistance to thermal shock	ISO 10545-9	resistant *	resistant *
chemical resistance	ISO 10545-13	class: from A to B	class: from A to C
stain resistance	ISO 10545-14	class: from 4 to 5	class: from 2 to 5
resistant to freeze-thaw	ISO 10545-12	resistant *	resistant *
fire reaction	EN 13501 (rev. 2005)	A2 - s1,d0	A2 - s1,d0
overall migration	UNI EN 1186	0 mg/dm ² no significant migration	no significant migration
VOC emission	UNI EN 16000-9	class A+ french	class A+ french
shock resistance	ISO 4211-4	no damage to ball drop 400mm	no damage to ball drop 400mm
light resistance	UNI EN 15187	5 no visible effect	5 no visible effect
thermal shock resistance	EN 14617-6	resistant	resistant
resistance to staining	ASTM C1378	resistant	resistant (except ink and methylene blue)

* Value relative to the ceramic body only

The unique features of Laminam products do not allow for a perfect comparison with ceramic tiles. The test results are therefore only indicative and not binding.

Technical specifications - furniture industry



physical and chemical properties	norm-test method	Laminam 20+	Laminam 20+ Lucidato
density	EN 14617-1 ASTM C97	2500 kg/m ³ (average value)	2500 kg/m ³ (average value)
water absorption	EN 14617-1	average value ≤ 0,1% *	average value ≤ 0,1% *
bending strength	EN 14617-2	50 MPa (average value)	50 MPa (average value)
freeze and thaw resistance	EN 14617-5	resistant	resistant
dry heat resistance	EN 12722 EN 438-2 par.16	5 (no visible effect till 200°C)	5 (no visible effect till 200°C)
chemical resistance	ISO 10545-13	from class A to B	from class A to C
chemical resistance	ASTM C650	resistant	resistant (except potassium hydroxide)
cold liquid resistance	EN 12720	5 no visible effect except ink (2)	from class 5 to 2
cleaner product resistance	PTP 53 CATAS	5 no visible effect	from class 5 to 3
abrasion resistance	EN 14617-4	28,0 mm	28,0 mm
hygiene properties	Metodo CATAS	excellent (high degree of removal of bacterial cells >99% after cleaning with a biocide-free detergent)	excellent (high degree of removal of bacterial cells >99% after cleaning with a biocide-free detergent)
resistance to fungi	ASTM G21	no fungal growth	no fungal growth
lead and cadmium given off	ISO 10545-15	0 mg/dm ³	0 mg/dm ³
overall migration	UNI EN 1186	0 mg/dm ² no significant migration	0 mg/dm ² no significant migration
VOC emission	UNI EN 16000-9	class A+ french	class A+ french
shock resistance	ISO 4211-4 EN 14617-9	no damage to ball drop 400mm average value 3 J	no damage to ball drop 400mm average value 3 J
light resistance	UNI EN 15187	5 no visible effect	5 no visible effect
thermal shock resistance	EN 14617-6	resiste / resistant	resistant
resistance to staining	ASTM C1378	resistant	resistant (except ink and methylene blue)

* Value relative to the ceramic body only

The unique features of Laminam products do not allow for a perfect comparison with ceramic tiles. The test results are therefore only indicative and not binding.

Technical specifications - furniture industry

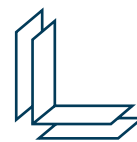

physical and chemical properties	norm-test method	1620x3240 Full Size Laminam 20+	1620x3240 Full Size Laminam 20+ Lucidato
Full Size: "length and width" nominal size: 1620x3240mm size / (63.7"x 127.5")	Laminam	minimum size: ≥ 1630x3250mm full size untrimmed	minimum size: ≥ 1630x3250mm full size untrimmed
weight	Laminam	average value 50,4 kg/m ²	average value 50,4 kg/m ²
surface quality / % pieces with no visible flaws	ISO 10545-2	> 95%	> 95%
water absorption	ISO 10545-3 / ASTM C373	average value ≤ 0,1% *	average value ≤ 0,1% *
breaking strength in N	ISO 10545-4	> 10000 * (sample dimensions 400x800 mm)	> 10000 * (sample dimensions 400x800 mm)
modulus of rupture in N / mm ²	ISO 10545-4	average value 50 * (sample dimensions 400x800 mm)	average value 50 * (sample dimensions 400x800 mm)
resistance to deep abrasion	ISO 10545-6	≤ 175 mm ³	≤ 175 mm ³
coefficient of linear thermal expansion / 10 ⁻⁶ /°C	ISO 10545-8	6,6 average value *	6,6 average value *
resistance to thermal shock	ISO 10545-9	resistant *	resistant *
chemical resistance	ISO 10545-13	class: from A to B	class: from A to C
stain resistance	ISO 10545-14	class: from 4 to 5	class: from 2 to 5
resistant to freeze-thaw	ISO 10545-12	resistant *	resistant *
fire reaction	EN 13501 (rev. 2005)	A2 - s1,d0	A2 - s1,d0
overall migration	UNI EN 1186	0 mg/dm ² no significant migration	0 mg/dm ² no significant migration
VOC emission	UNI EN 16000-9	class A+ french	class A+ french
shock resistance	ISO 4211-4 EN 14617-9	no damage to ball drop 400mm average value 3 J	no damage to ball drop 400mm average value 3 J
light resistance	UNI EN 15187	5 no visible effect	5 no visible effect
thermal shock resistance	EN 14617-6	resistant	resistant
resistance to staining	ASTM C1378	resistant	resistant (except ink and methylene blue)

* Value relative to the ceramic body only

The unique features of Laminam products do not allow for a perfect comparison with ceramic tiles. The test results are therefore only indicative and not binding.



Laminam12+
1620x3240

Kitchen
Laminam Showroom Fiorano
In-Side,
Porfido Marrone Naturale

2 | Packaging and packaging materials



Laminam 12+ and 20+ Full Size 1620X3240 slabs are packaged and positioned vertically on IPPC_FAO “A Frames” in galvanised metal.

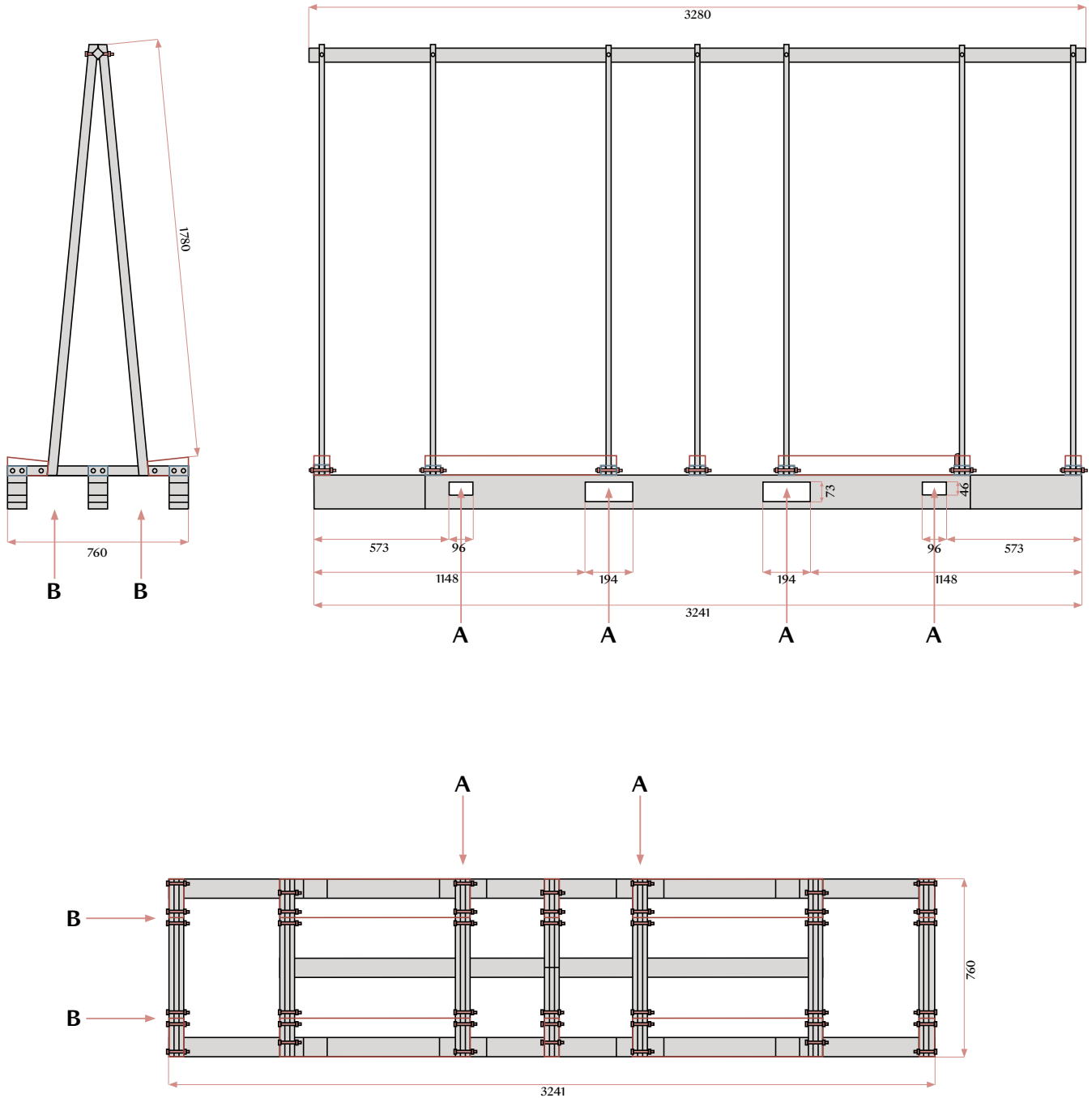

For transport in 20' containers, Laminam 12+ and 20+ Full Size 1620X3240 slabs can be packaged on Big A frames, with dimensions and characteristics that are different from the regular A-frame, so that it can carry a greater number of slabs.

sizes /mm	pcs per A-frame	sqm per A-frame	kg per A-frame	mm total A-frame size /inch
Laminam 12 + Full Size* 1620x3240 mm 63.7"x127.7"	20	105	3310	3280x760x1970h 129.1"x29.9"x77.5h"
Laminam 20 + Full Size* 1620x3240 mm 63.7"x127.7"	12	63	3335	3280x760x1975h 129.1"x29.9"x77.7h"

sizes /mm	pcs per Big-frame	sqm per Big-frame	kg per Big-frame	mm total Big-frame size /inch
Laminam 12 + Full Size* 1620x3240 mm 63.7"x127.7"	120	630	19011	3280x2220x1755h 129.13"x87.4"x69.09h"
Laminam 20 + Full Size* 1620x3240 mm 63.7"x127.7"	72	378	19351	3280x2220x1755h 129.13"x87.4"x69.09h"

Laminam slabs are packaged with a thin layer of wax placed between the slabs in order to protect the surfaces. Before processing the slab, we suggest removing the wax with a wooden spreader and denatured alcohol.

* Untrimmed end product.

Below are examples of loading schemes for Laminam 12+ and Laminam 20+ slabs, which can vary depending on the type of vehicle, capacity and destination country. These indications must be verified against the current regulations in the destination country.

A-Frame			
Laminam 12 + Full Size* 1620x3240 mm 63.7"x127.7"	Container 20'	Container 40'	Lorry (13.60m)
A-frames for loading	3	8	8
Slabs for loading	60	180	180
Sqm for loading	315	945	945
Max total weight	9.840	26.230	26.230

A-Frame			
Laminam 20 + Full Size* 1620x3240 mm 63.7"x127.7"	Container 20'	Container 40'	Lorry (13.60m)
A-frames for loading	3	8	8
Slabs for loading	36	108	108
Sqm for loading	189	567	567
Max total weight	10.005	26.685	26.685

Big A-Frame		Big A-Frame	
Laminam 12 + Full Size* 1620x3240 mm 63.7"x127.7"	Container 20'	Laminam 20 + Full Size* 1620x3240 mm 63.7"x127.7"	Container 20'
Big A-frames for loading	1	Big A-frames for loading	1
Slabs for loading	120	Slabs for loading	72
Sqm for loading	633	Sqm for loading	378
Max total weight	19.011	Max total weight	19.351

* Untrimmed end product.

3 | Handling and storage



Laminam 1620x3240mm slabs must be handled under safe conditions and in such a way as to preserve their original appearance and prevent accidental breakage. We recommend extreme care during handling phases to ensure that the area is clear and people are not walking through.

3.1 Moving A-Frames with a lift truck (forklift)

Before the handling phase, the A-frame must be loaded symmetrically to avoid problems of instability. The operator must verify that the slabs are secured to the A-frame with the specific hoops before beginning the handling process. It is important to be very careful when handling the material because the outer edges of slabs loaded onto the A-frames are not protected.

A-frames have two grab points for handling with the lift truck:

“A” is the transversal grab point; center distance of at least 740mm.

“B” is the longitudinal grab point.

Use a lift truck with a suitable maximum load capacity. Laminam slabs loaded on A-frames in the warehouse or at the manufacturer must be handled preferably using the “A” transversal grab point. This means loading the A-frame on the lift truck on the 3240mm side, using forks that are at least 1200 mm long and a lift truck with a capacity of at least 5000 Kg. If instead it is decided to use the “B” grab point, it will be necessary to use a lift truck with a capacity of 5000 Kg with forks extending at least 2800 mm in length. Make sure that the load is balanced and stable on the forks and that it does not sway. During the loading and unloading phases, from the lorry and the container, insert the forks under the A-frame with the help of the two grab points “A” and “B” as specified in the following paragraphs. When loading/unloading and in subsequent transport of even one single slab, secure the slab(s) to the A-frame with hoops/bands in cloth or plastic. Do not use metal chains to secure the slab. Before freeing the material from the hoops that secure it to the A-frame, make sure that the A-frame is positioned on a level surface to avoid any risk of the slabs falling.

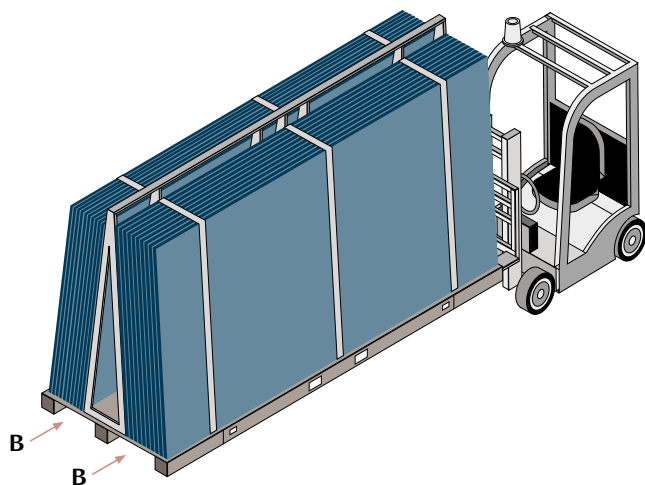

A-frame forked in grab point B,
using long forks at least 2800 mm

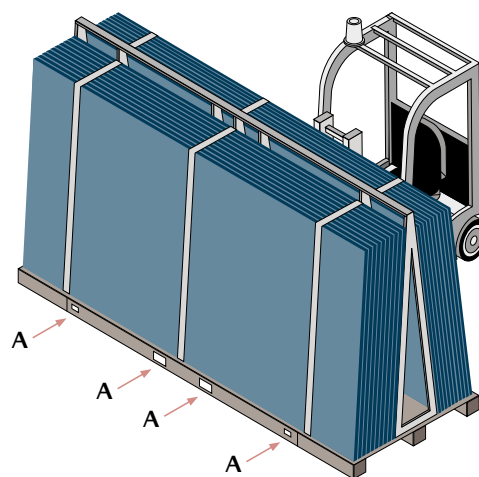

A-Frame inforcato dal punto di presa A
with a space in-between of at least 740mm

3.1.1 Loading/Unloading A-Frames on/from Lorries

To load or unload slabs on a lorry with an openable bed, position the lift truck forks under the A-frame in the two “A” grab points with a center distance of at least 740 mm.

Use forks with a minimum length of 1200 mm to and place the A-frame in a central position on the lorry.

To safely transport slabs on lorries, fasten the A-frames to the lorry bed by securing them at the base of the wooden platform and also at the tallest point of the metal structure. Use suitable straps in polyester or similar materials to secure the A-frames. To load other rows of A-frames, make sure the distance between the slabs is at least 50 mm.

Before unloading, always check to see how the A-frames were blocked so that you can effectively remove those blocks.

When loading and unloading, the operator must pay attention to people in the surrounding areas and avoid instability of the load. For this reason, the load must always be kept low during transport and raised only when it is near enough to the lorry to be loaded.

Below is an example of loading an A-frame on a standard lorry 13.60 m in length.

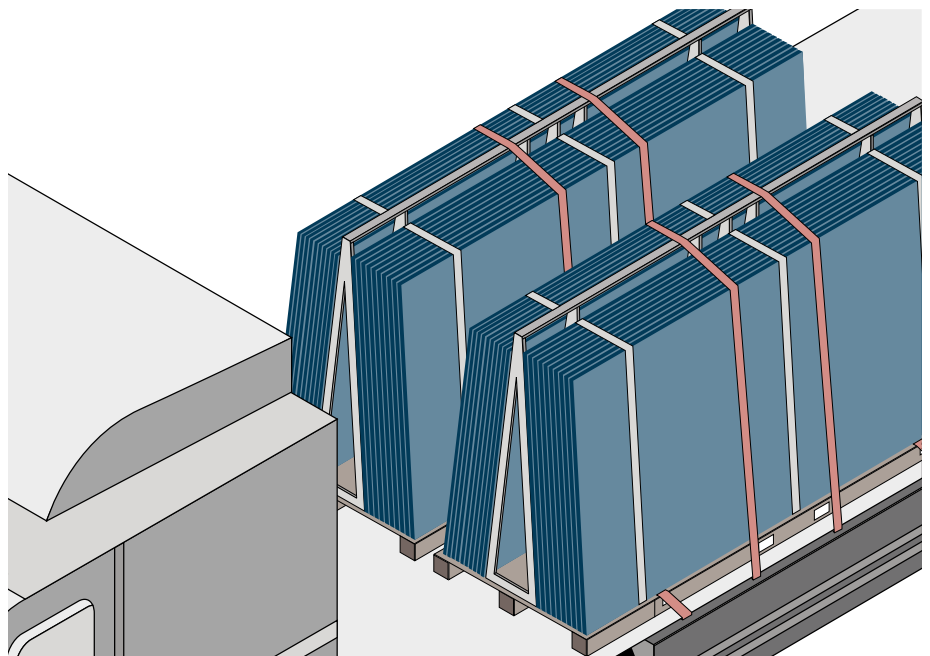
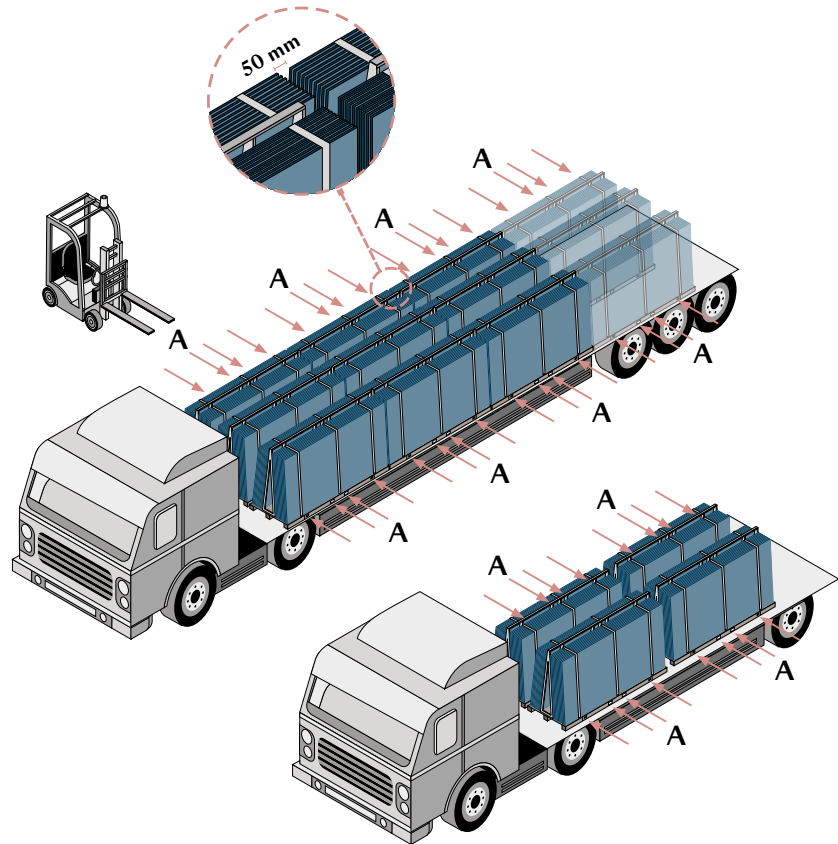

3.1.2 Loading/Unloading A-Frames into/from Containers

Use a pallet mover or lift truck with 5000 kg capacity, with extensions of a minimum length of 2.80 m during the loading and unloading phases of the material if using a container. The operator handles the full A-frame, picking it up and lifting it from the two “B” grab points.

When loading, verify the correct stability of the material, and tie and fasten the A-frames together and to the cargo area. For safe transport in containers, fill the empty space between A-frames and rows of A-frames with airbags.

Before unloading, always check to see how the A-frames were blocked so that you can effectively remove those blocks. Outside the container, always handle the material by lifting the A-frames with the “A” grab points.

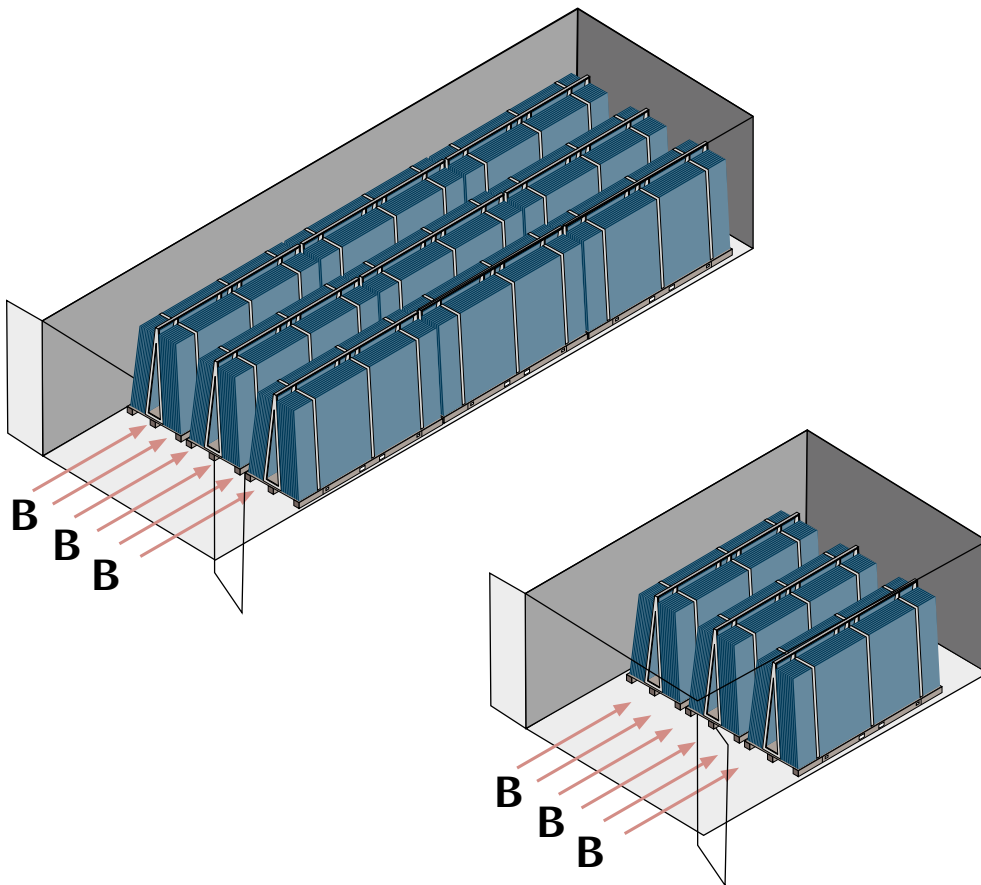

3.2 Handling and Loading/Unloading Big A-Frames

The Big A-frame is directly assembled inside 20' containers by Laminam personnel. The central nucleus of the A-Frame is made up of three metal elements set at equal distances apart by tubular pieces. At the base of these elements, two wooden platforms marked FAO are prepared where the slabs will be placed.

To preserve the integrity of the slabs during transport, wooden elements called “stoppers” are positioned on the front and rear of the container to keep the slabs from moving in a longitudinal direction. To limit transversal movement of the slabs, four airbags are inflated on site, just before the container is closed, and set on the sides of the A-frame.

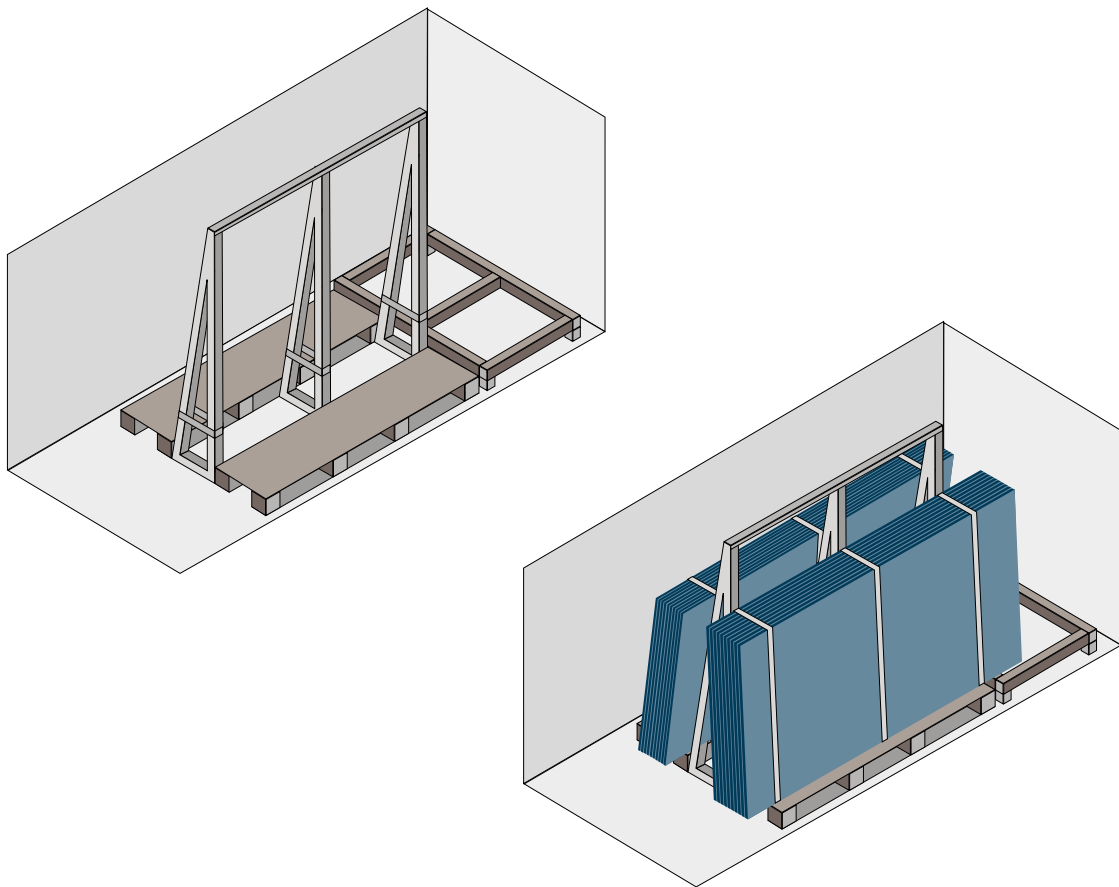

The slabs are packaged and loaded in groups of ten for 12+ and of six for 20+. To load/unload these groups of slabs, it is necessary to use lifting equipment with straps similar to the photo below, mounted on a lift truck with a 7000 Kg capacity. Alternatively, a crane can be used with a lifting arm that is usually used for handling marble slabs.

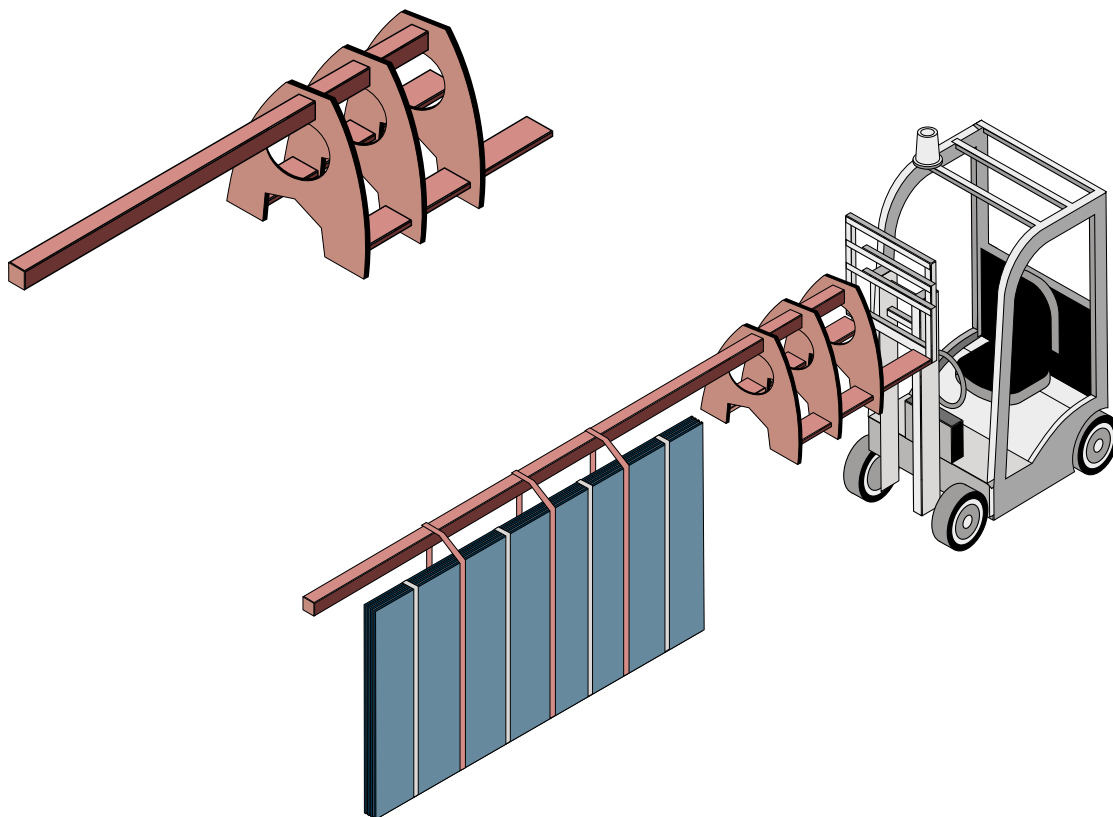

These groups of slabs must be loaded symmetrically to keep the structure balanced and to place 20 for 12+ and 12 for 20+. Place a 2 cm sheet of polystyrene between the slabs to allow the straps to be inserted during the unloading phase.

To increase safety and stability of the container, the groups of slabs must be tied together with hoops. When unloading, we suggest using a similar tool and the same operative method to avoid unbalanced loads and accidental breakage.

3.3 Handling a single slab

When removing the Laminam Full Size 1620x3240 12+ and 20+ slabs from the A-frames, it is necessary to alternate sides for greater safety. Removing one slab from one side and the next slab from the other keeps the load symmetrical and more stable.

To move one single Laminam slab and position it on a rack or a machine that will process it, it is possible to use suction pad lifting equipment with several grab points supported by an overhead travelling crane or a jib crane, depending on the weight of the individual slab.

The single slab can also be moved with cloth straps coated in rubber. Never use chains or steel cable because these materials can damage the ceramics. In fact, chains and steel would scratch the surfaces of polished materials and could leave steel residue on natural materials which would then require careful cleaning.

If handling with grippers, insert rubber grip covers to protect polished Laminam slabs.

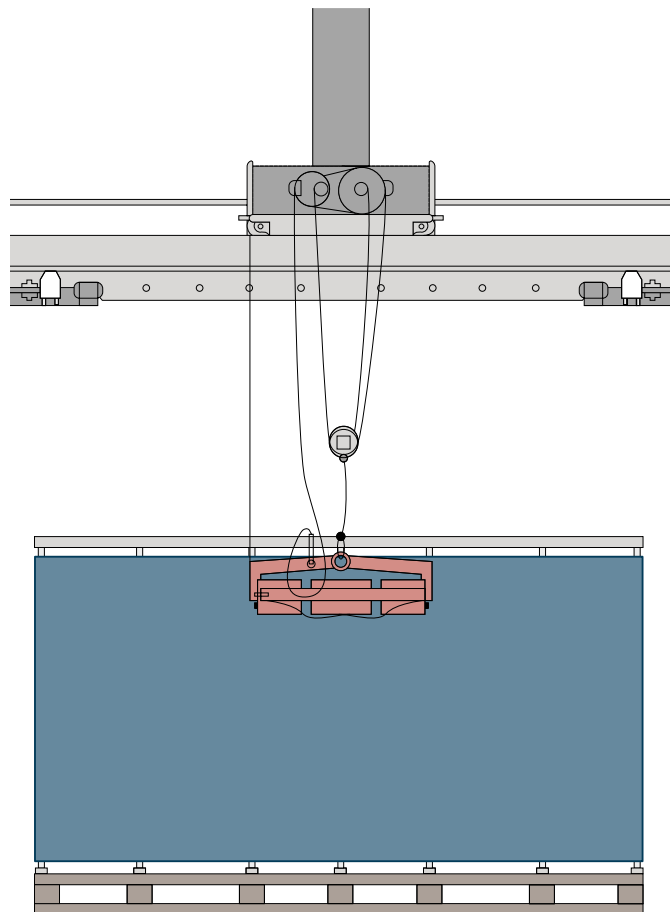

3.4 Storing the Slabs

Laminam slabs can be stocked in warehouses on specific supports and metal structures like tripods or racks, suitably constructed and with protective structures in wood, rubber or plastic where the slabs will be positioned vertically. The A-frame used for packaging the Laminam slabs can also be used to store them. Safely store the material using dedicated wedges or belts to prevent sliding.

If stored outside, it is advisable to make sure that the stability of the A-frame is guaranteed in case of harsh weather. The slabs set vertically on the A-frames will bend slightly when they are set down. This is not a defect of the product and does not compromise processing in any way. This bending disappears when the slab is set on a horizontal surface.

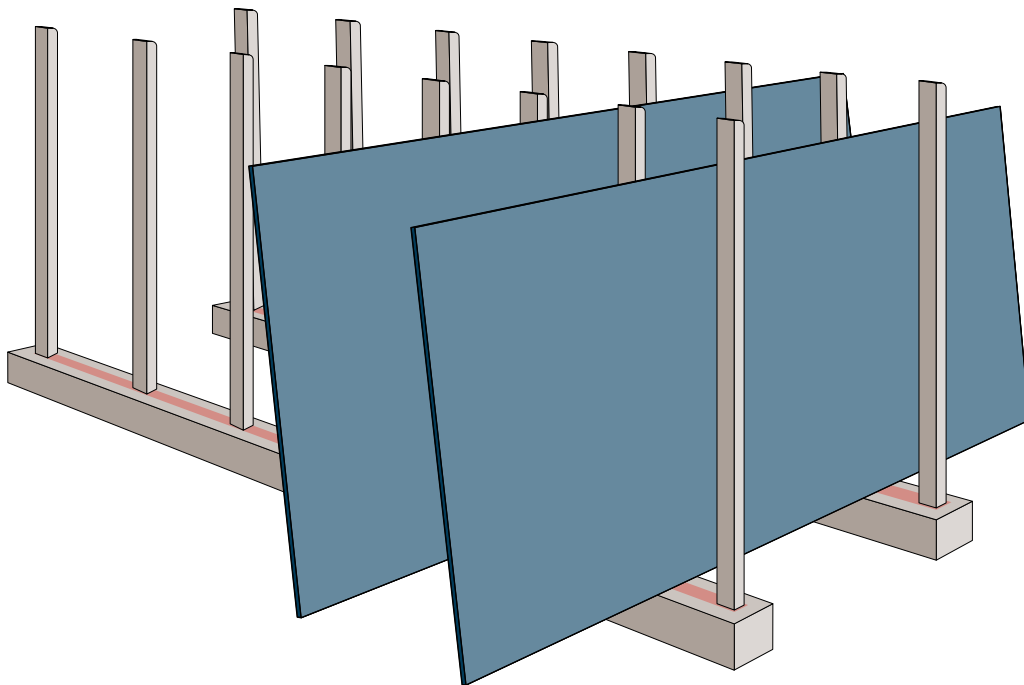

Regardless of the storage method, we advise not setting other materials on top of Laminam slabs, especially on polished finishes (Lucidato). If it is necessary to place something on the slab, separate the materials with appropriate spacers.

When storing slabs with polished finishes, insert spacers (such as polystyrene sheets or wooden slats) between them if the wax coating cannot be guaranteed, or if the wax is not sufficient to prevent contact between the slabs during their handling at a later time

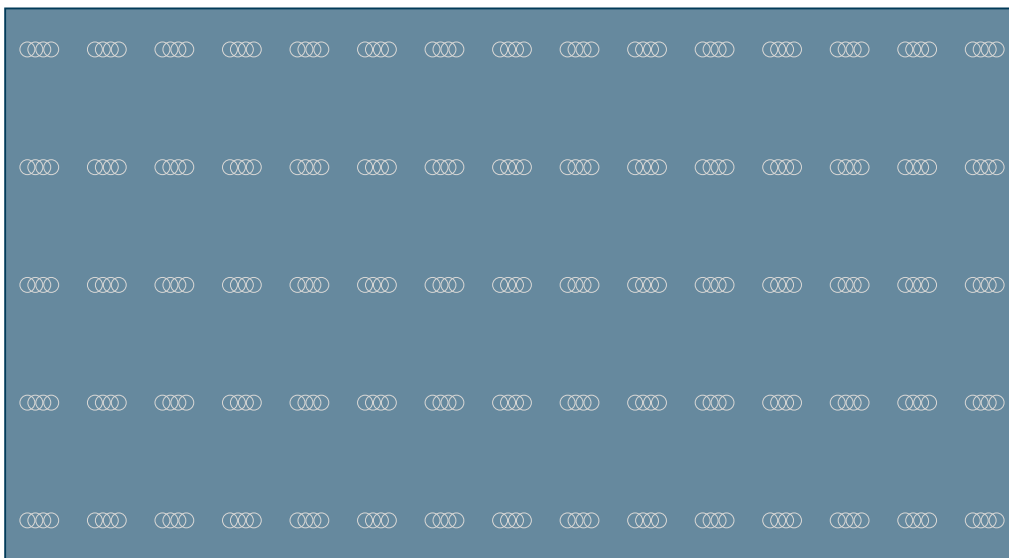

Wax spacers

4 | Quality Control on Laminam 12+ and Laminam 20+



The Laminam 12+ and Laminam 20+ slabs are made of natural raw materials and carefully produced and selected in accordance with the high quality standards that Laminam S.p.A has set as objectives.

The manufacturer (slab processor) must inspect the slab before beginning processing operations and after careful cleaning of the surface under inspection.

Any nonconformities that emerge must be reported before the slab is processed.

Laminam S.p.A will not accept defect reports or claims after the slab has been processed and/or installed.

4.1 Dimensions

The term “Full Size” means that the slab has ended the production cycle without being trimmed. This is the size destined to be processed, because it gives manufacturers the opportunity to optimize their possible cutting schemes depending on the project.

The size with dimensions 1620x3240 mm can be obtained from each slab, which corresponds to the useable surface area and the billable quantity.

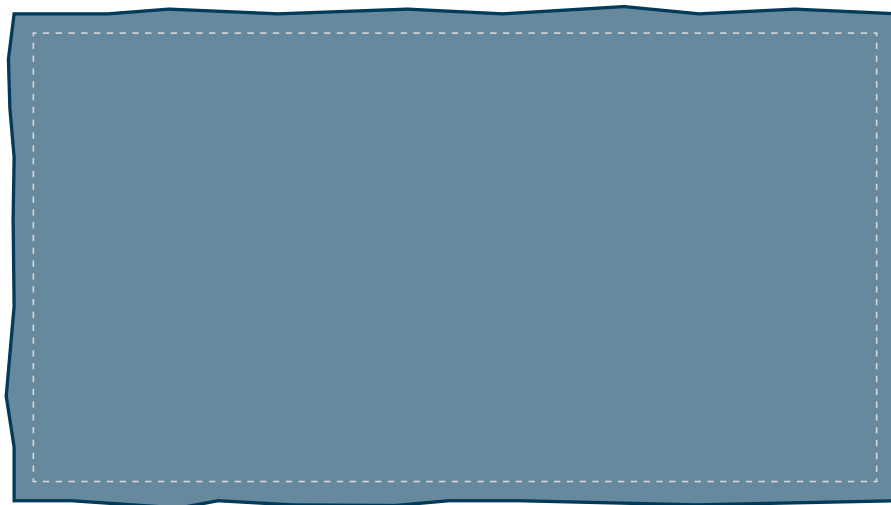

4.2 Thickness

Laminam 12+		Laminam 20+	
Nominal thickness Laminam 12+	12,5 mm	Nominal thickness Laminam 20+	20,5 mm
Tolerance	+/- 0.5 mm	Tolerance	+/- 0.5 mm

4.3 Planarity

To verify planarity, position the single Laminam slab with the decorated face turned upwards on a reference surface, for example in metal, which is perfectly horizontal and stable.

Do not check planarity when the slab is in a vertical position because it will bend. The max 2mm tolerance refers to a full size slab and also to non-standard sizes which have been cut from a full size slab.

Laminam 12+ Planarità		Laminam 20+ Planarità	
Side 1620 mm	max 2 mm	Side 1620 mm	max 2 mm
Side 3240 mm	max 2 mm	Side 3240 mm	max 2 mm

Concave planarity can be verified using a perfectly flat horizontal surface as a reference and a thickness gauge of 2mm representing the flexure tolerance of the slab. If the thickness gauge does not pass underneath, there is no problem with planarity.

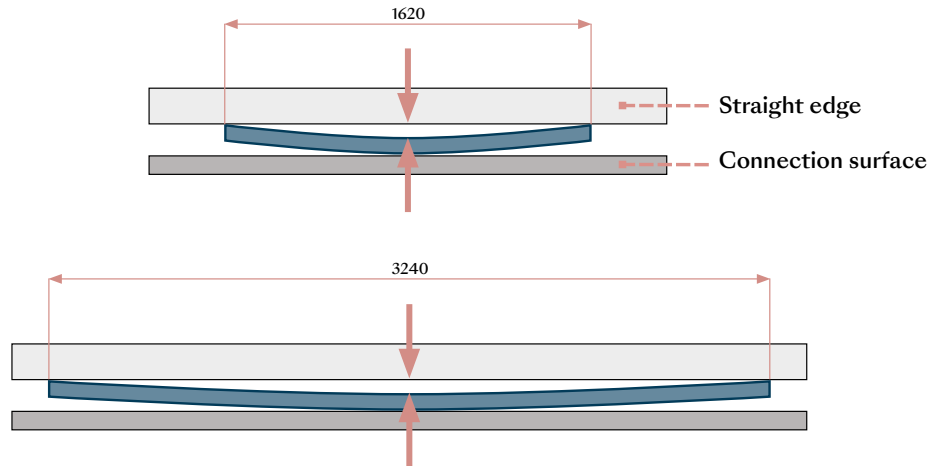

Convex planarity must be measured with an aluminum rod held parallel with one of the sides to verify. It is possible to assess the portion of the slab which presents a possible flexure by using a 2mm thickness gauge. If the thickness gauge does not pass underneath, there is no problem with planarity.

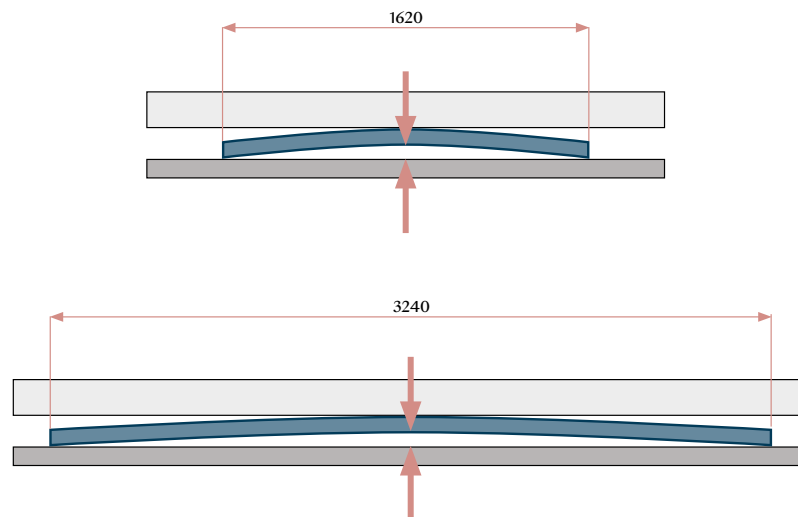

4.4 Shade

Laminam 12+ and Laminam 20+ slabs are produced from natural raw materials and obtained through an industrial process. Even though they are not subjected to important aesthetic variations like natural stones, the type of raw material used to manufacture them ensures that there are minimal chromatic variations. The production process at Laminam S.p.A. involves an attentive selection phase to identify and mark the different shades, thus guaranteeing that the product always be within the company's predetermined tolerance margins. These variations are to be considered a natural characteristic of Laminam slabs. Slabs with the same finish but different dimensions and thicknesses will always have a different shade, but this will always be in the company's preset range. In building projects, we suggest not placing slabs of the same finish and different thicknesses, which have different shades, side by side on the same floor. A single package of slabs can contain several shades of the same finish, and this information will be marked on the label on each slab. Therefore, it is necessary to verify the uniformity in shade to build projects that require the use of several slabs. Each shade is not repeatable. If the finish is still in production, on request, Laminam S.p.A. can search the material available in the warehouse and supply the shade closest to the slabs purchased previously.

4.5 Surface Quality

Laminam slabs are obtained through the use of natural raw materials which have been fired at high temperatures (> 1200°C). These conditions can cause the formation of irregularities typical of natural products. Some of these characteristics can be considered as covered by the tolerance, but others will cause the slab to be declassified.

Laminam S.p.A classifies two distinct categories of Laminam 12+ and Laminam 20+ slabs, in terms of surface quality: Q1, first pick; Q2 second pick. In accordance with the ceramic regulations of the sector, the aesthetic conformity of the surface of Laminam materials must be verified by visual inspection by placing the slab in a horizontal position, with natural or artificial light aimed perpendicularly at the surface being observed (not backlighting) at a distance of not less than 1 m.

Q1– first choice

This category includes Laminam slabs that comply with the following surface tolerances:

Irregularity* similar colour	Radius: ≤ 3 mm
Irregularities* different colour	Radius: 1 mm
Scratches (polished surfaces)	Defects that are visible with natural light from a distance of 1 m on mechanically processed surfaces are nonconformities.

Q2 – second choice

Anything that does not make the Q1 category except for cracks/broken angles greater than 20 cm. This material is declassified to 2nd pick (Q2).

*Irregularities are: dots, roughness, holes/hollows.

4.6 Variations in graphics on materials

Each series of Laminam products is made in one or more graphics. Slabs with the same graphics present minimal deviations of pattern symmetry, which mimic the characteristic variety present in natural materials. This feature could be more evident in the graphics that represent veining.

In the series that feature book match, at the same level of centering, the tolerance in the graphics between slabs ranges within 3cm, except for when the manufacturer obtains a better result by verifying the point of cutting and joining the slabs.

4.7 Labelling and marking

Every Laminam slab is identified with a label bearing important information about the product code, shade, size, production date and time, quality and finish.

The website URL www.laminam.com is also on the label, where technical information about the product is available. The label bears a 12-character serial number that uniquely identifies the slab produced. This information can be found within the label's QRcode.



The following references are printed on one of the short sides of the slab to enable slab recognition during warehouse storage: item code, shade, choice, serial number (only for Q1) and item description.

Es.: F009913 815_B Q1 B12420886007 I NAT.ARDESIA NERO A SPACCO 1620X3240 XL Lam. 20+

5 | Guidelines for designing top surfaces and furnishing complements with Laminam 12+ and Laminam 20+ slabs



5.1 Minimum distances from the edges

Always design kitchen countertops with a minimum of 50mm from the external edge in the presence of holes and cutouts. The same minimum distance must be kept also with adjacent openings.

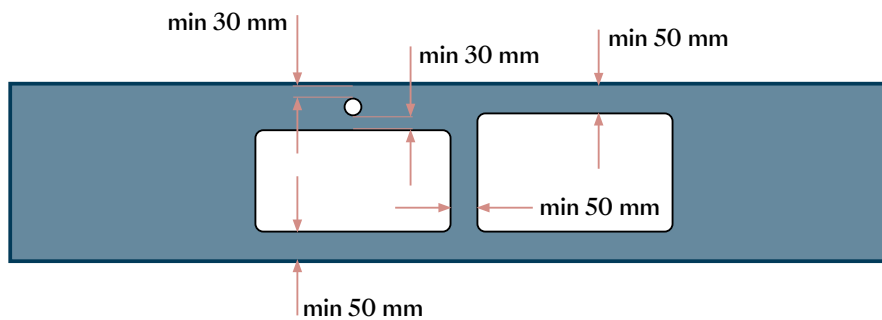

5.2 Internal Angles

To create internal angles and openings, make a fitting in correspondence with the minimum radius equal to 5 mm, to distribute stresses, like which processing natural stone, marble and composite stone

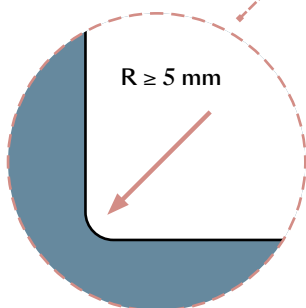
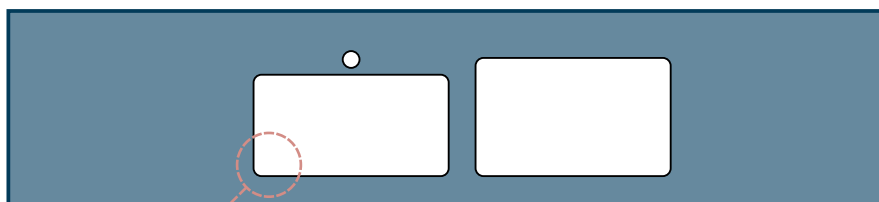

The creation of internal 90° angles is not advisable. Like for all rigid materials such as marble, natural stone, composite quartz, and glass, it may be done under the responsibility of the operator on the basis of his/her own experience, with processes that the operator has tested and deems suitable.

This processing increases the possibilities of crazing during the phases of handling, manufacturing, transport and installation of the surface and the subsequent settling of the different kitchen base units.

5.3 Designing holes for sinks and hobs

Processing Laminam 12+ and 20+ slabs to obtain holes for the placement of sinks or appliances must be done only after careful assessments of the processing measurements shown on the technical sheet of the product to install, depending on the installation method.

A minimum distance of at least 2 mm is required between the hob and the Laminam slab, to accommodate thermal expansion, unless a greater distance is envisaged by the appliance manufacturer. The gap must be filled with an appropriate sealant.

Stove installed on countertop

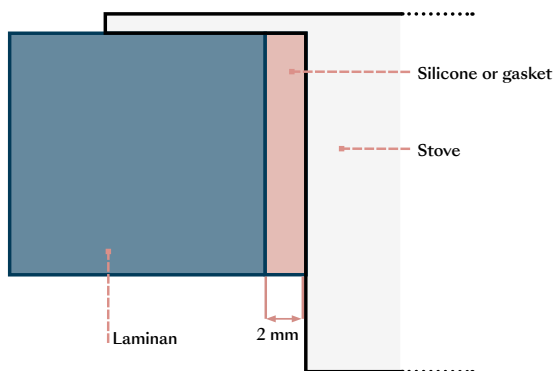

Stove flush with the countertop

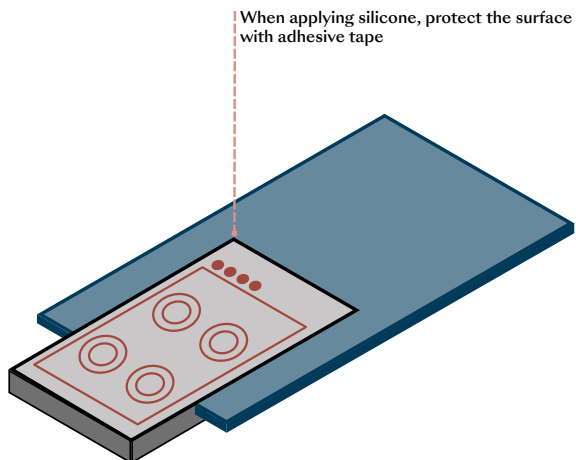
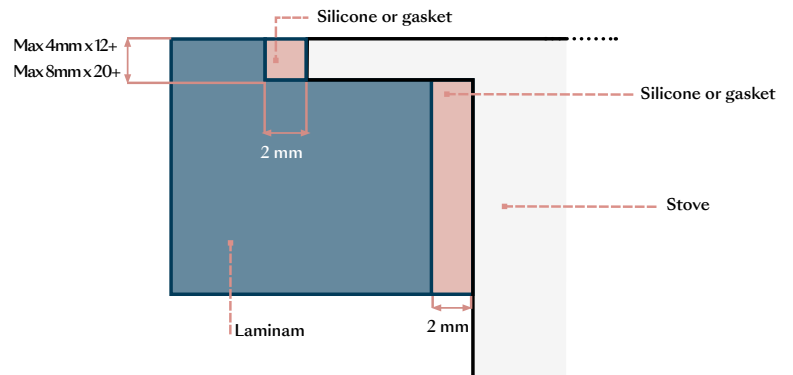

Regardless of the type of sink defined in the project, support bars or other equivalent systems must be fixed to the unit structure to hold the weight of the slab and the water that it can contain, so that it will not be dependent on the slab.

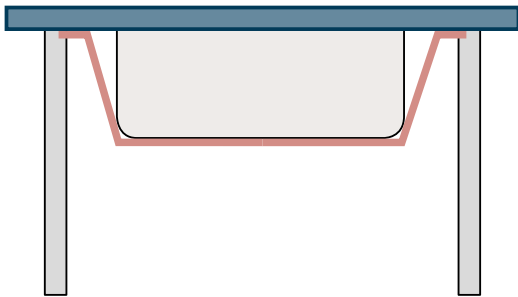
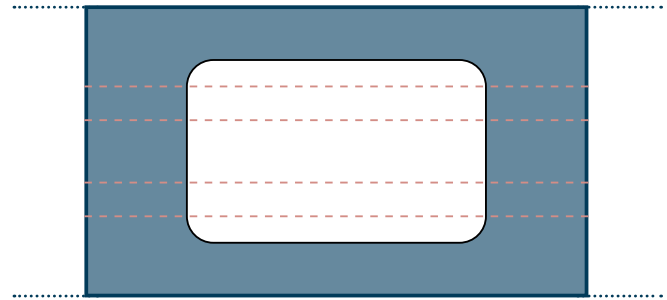
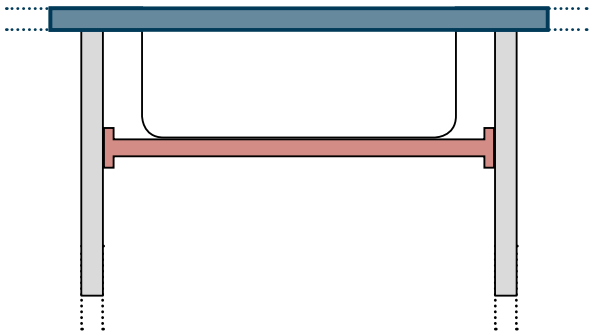

If the base unit has sliding drawers, these supports must be suitably shaped to allow them to slide properly.

With regard to the project (such as in case of repeated grooves close together), assess the possible need for reinforcing the perimeter of the cutout by applying a Laminam slat with a suitable adhesive under the countertop.

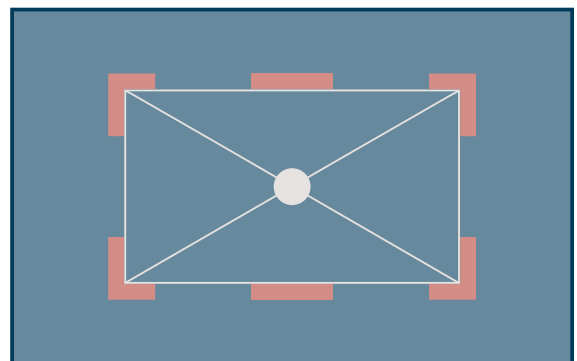
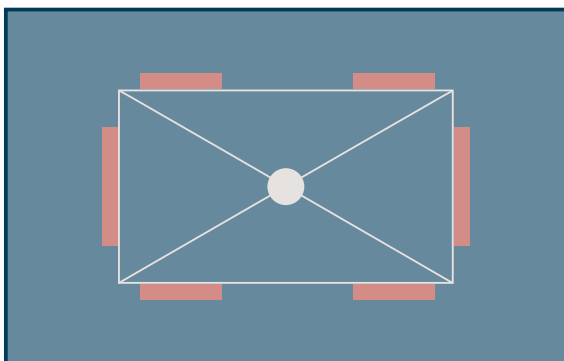

Laminam12+ and Laminam 20+ slabs can be processed to obtain different configurations for sinks and hobs.

5.3.1 Overtop Installation

This is a simpler, more traditional type of installation, which involves having a protruding edge a few millimeters wide overlapping the countertop.



5.3.2 Flush Installation

The flush sink/hob is inserted into a hole that has a maximum depth of $\frac{3}{4}$ millimetres carved out of the Laminam 12+ slab and $\frac{6}{8}$ millimeters on the Laminam 20+ slab.

The depth of the hole varies depending on the thickness of the edge of the sink or hob to install in the countertop. This is a practical solution for cleaning, but it requires more care during assembly.

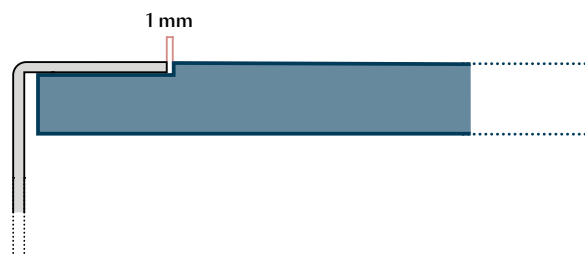

5.3.3 Undertop Installations

Used for sinks, this solution makes it possible to have surface uniformity on the countertop because there is no edge. To increase the resistance of the Laminam 12+/20+ slab edge near the hole, make a bevel of at least 2mm. Consider that rounded bevels guarantee greater resistance to shock.

This type allows the use of Laminam sinks made as per indications in the following paragraph.

This solution facilitates cleaning and hygiene of the countertop, given the absence of protrusions that can trap dust and dirt.

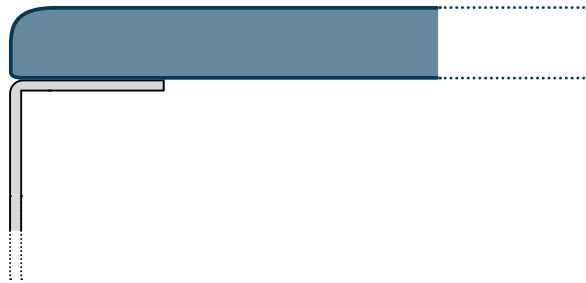

5.3.4 Installation with 45° fitting

The 45° integration of the countertop with the sink is possible when the sink is made of Laminam material, as indicated in the subsequent paragraph 5.6. It requires holes at 90°, and all indications listed in the paragraph 5.2 remain valid.

5.4 Creation of lowered areas in the countertop to place the sink

Some counters are designed so that the area around the sink is lower than the top surface. To avoid mounting slats horizontally to compensate for the two heights, we suggest limiting the lower depth to 8mm for 12mm slabs and 12mm for 20mm slabs.

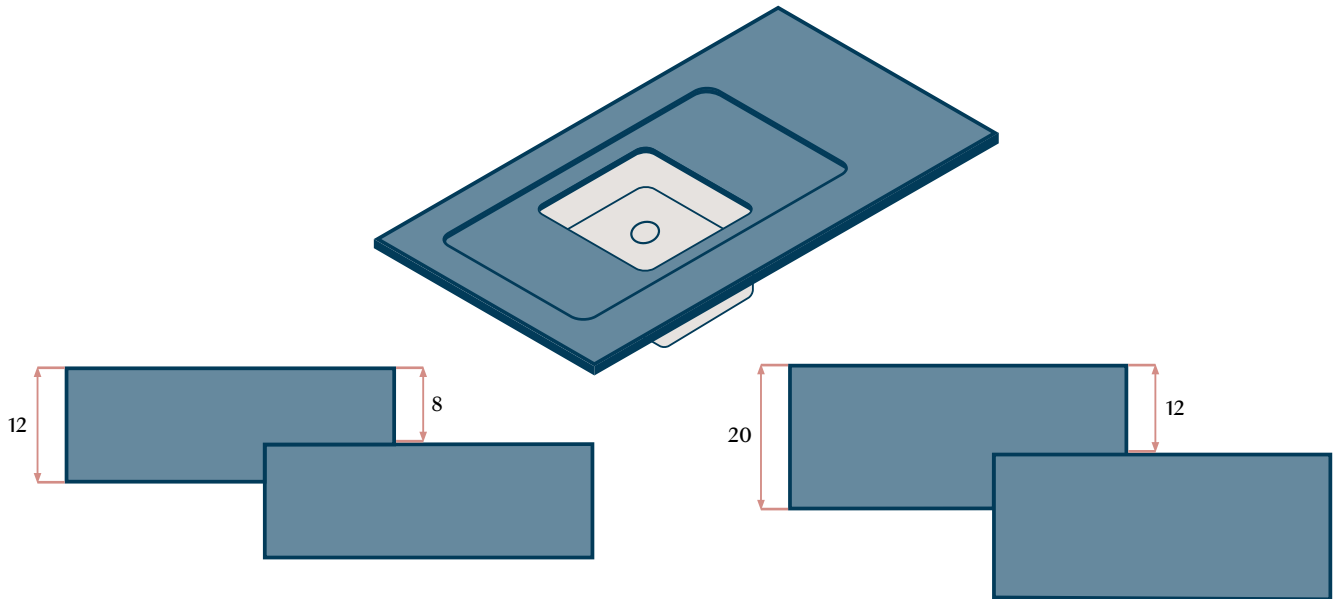

This method allows the lowered part of the countertop to remain horizontal, and therefore the perimeter around the sink can contain the dispersion of liquid without spilling over onto the rest of the top.



In this lowered portion, it is possible to mount any type of sink in all methods described above. To guarantee the correct installation of this type of top on all kitchen base units, it will probably be necessary to adapt the vertical profiles of bases in the lowered areas. If the countertop requires the presence of a frontal horizontal reinforcement, a suitable lightweight material (like Eulite) can be installed to restore a horizontal area to apply directly to the kitchen base units.

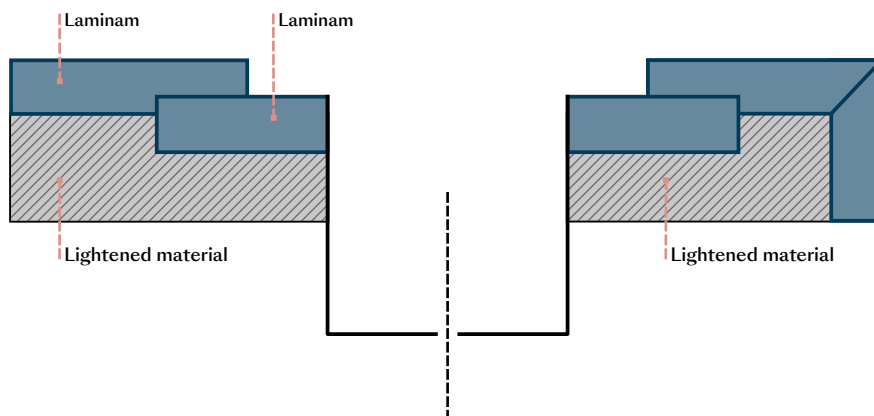

5.5 Creating a dripstone on Laminam countertops

Near the sink cutout, it is possible to make drip catcher channels with a suitable grade to make the water drain into the sink. These channels can be made with specific tools mounted on CNC machines or with specific disks on disk machines.

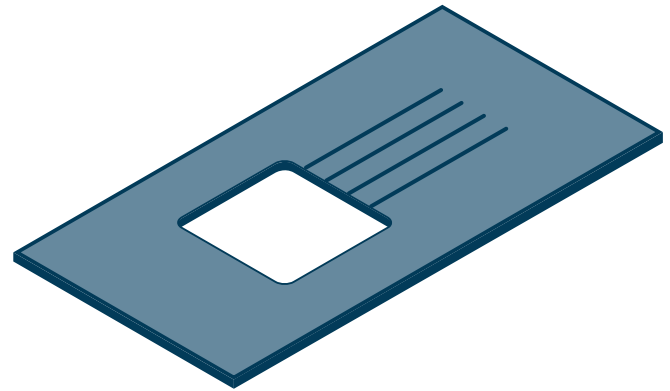

The product abraded does not offer the same characteristics as the slab.

For this reason, the surface which has been subjected to these processes must be treated with specific products to restore the characteristics of non-absorbency and stain resistance. On these portions, Laminam does not guarantee the level of performance listed in the technical sheets.

The manufacturer is responsible for applying the treatment with a suitable product, after having run the proper internal tests independently. When the countertop is delivered to the final client, the manufacturer agrees to inform the client about which treatments must be applied subsequently to maintain performance levels.

The use of these products could cause the slab shade to vary slightly. Laminam advises against abrading on light-colored finishes. For this purpose, the IN-SIDE finish guarantees overall product compatibility.

Please consult the Technical Sheets of the manufacturer for instructions about the correct application of the selected product.

Producer	Protective product for edges and surface abrasions	Website
Fila Solutions	Stop Dirt	www.filasolutions.com
Tenax	Ager	www.filasolutions.com
Akemi	Colour Bond (For interiors) Akepox 5010 colour cartridges (For interiors)	www.tenaxceramica.it

5.6 Sinks Made in Laminam Ceramic

A sink made in the same surface material as the countertop is a functional, practical aesthetic solution that harmoniously integrates the sink with the rest of the architecture and design of the kitchen where it is installed. There are several methods for building a sink in Laminam ceramic, which vary from manufacturer to manufacturer based on the specific experience. Since the material can be processed using the same technology required for natural stone, the architectural solutions are possibly infinite for creating surfaces on several levels, and therefore also sinks.

Below, a few of the more popular methods are described, requested for their high level of artisan craftsmanship. Manufacturers can guarantee these methods exclusively because they are an expression of each artisan's own experience. This information provides a rough indication and is not binding.

Since the manufacturer must guarantee the sink and considering the particular nature of the processing and the high level of artisan craftsmanship necessary, we suggest making mock ups and subjecting them to the normal stresses of use to offer the client a tested solution. These items usually require care during packing, transport and installation, and attention to all attachment points that must guarantee stability over time.

5.6.1 Making the sink bottom

When making the sink, it is important that the bottom part guarantee that water can run off correctly and allow correct cleaning.

Sink bottoms can be made:

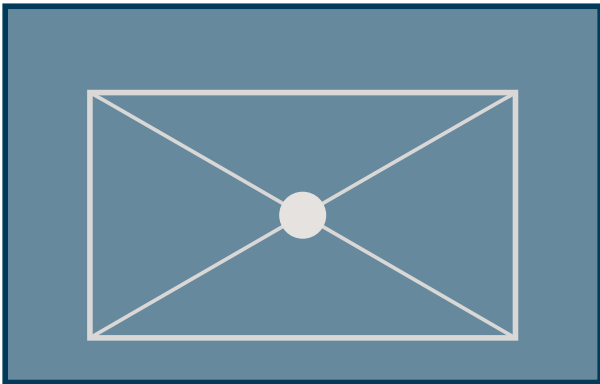

By using more than one portion of slab specifically shaped and glued together to create the right slant towards the drain.

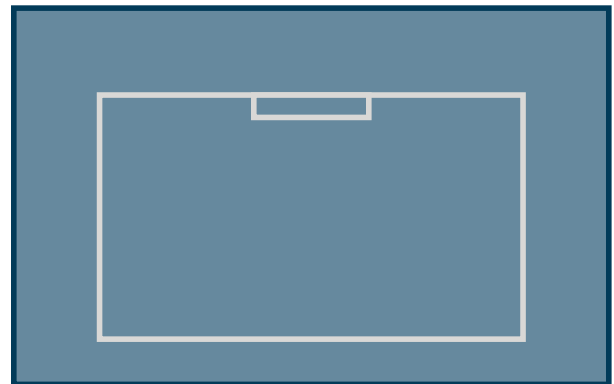

With a single removable piece of slab when mounting a readily serviceable drain that flows into a containment tank.

By abrading a portion of slab to form the base for setting the sink walls and the correct slope towards the designed drain point.

This process can be performed on IN-SIDE finishes, which are overall compatible with the surface finish, not including veins present in the thickness.

The slab thus processed will, anyhow, present differences in shade and graphics even after treatment, compared to the original slab, without this being considered a defect. For a uniform internal sink surface, repeat the process also on the vertical areas, if necessary.

For Laminam 20+, we suggest creating a min. 5 mm rounded connection between the perimeter portion forming the base of the walls and the rest of the bottom, to ensure easy cleaning.

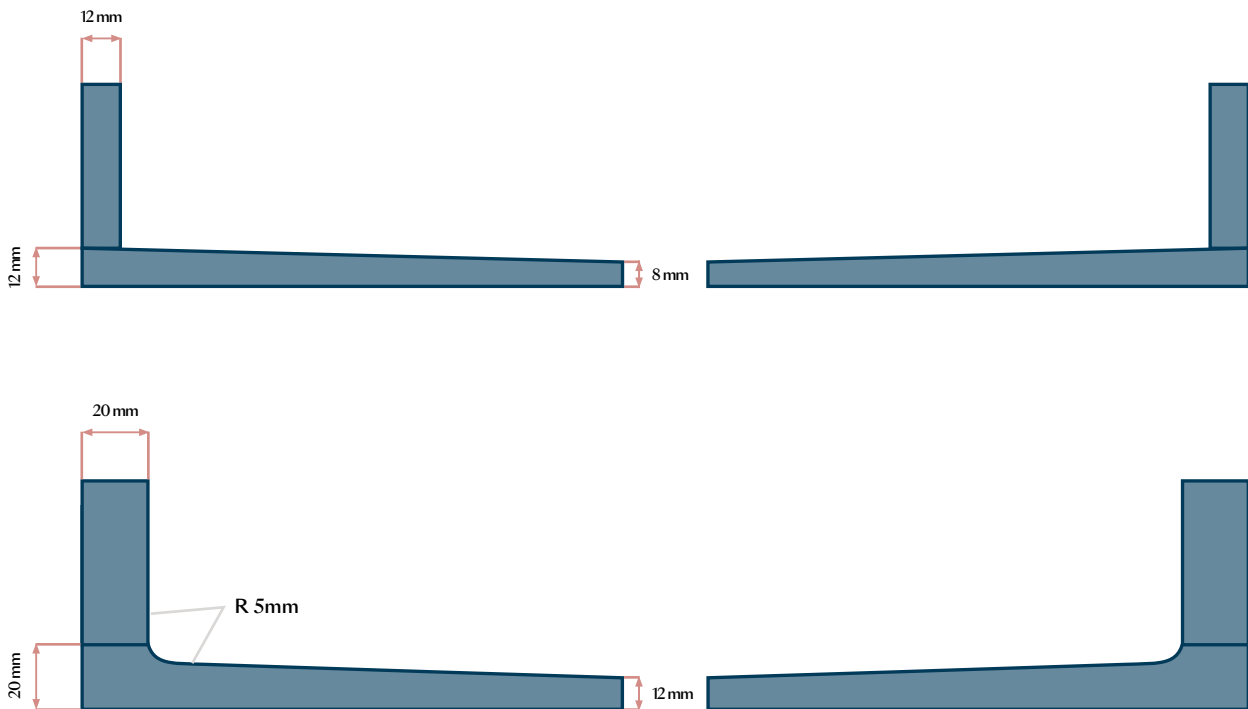

From this edge to the drain point, the bottom slab will be abraded to give it the right slope. This processing is generally done with a technique that has already been used to shape natural stone, using tools and parameters that are suitable for stoneware.

The ceramic surface obtained in this manner must be treated with specific products to restore the characteristics of non-absorbency and stain resistance as indicated in paragraph 5.5. On these portions, Laminam does not guarantee the level of performance listed in the technical sheets.

5.6.2 Making a sink with a tilted integrated drip catcher

Both types of basins created in Laminam ceramic, in the two methods described below, can be integrated with an inclined portion of slab that functions as a drip catcher and is joined to the rest of the countertop. Inclining a portion of slab directly instead of abrading it to create a slope, or creating inclined channels (large grooves), will maintain the surface characteristics of the material intact.

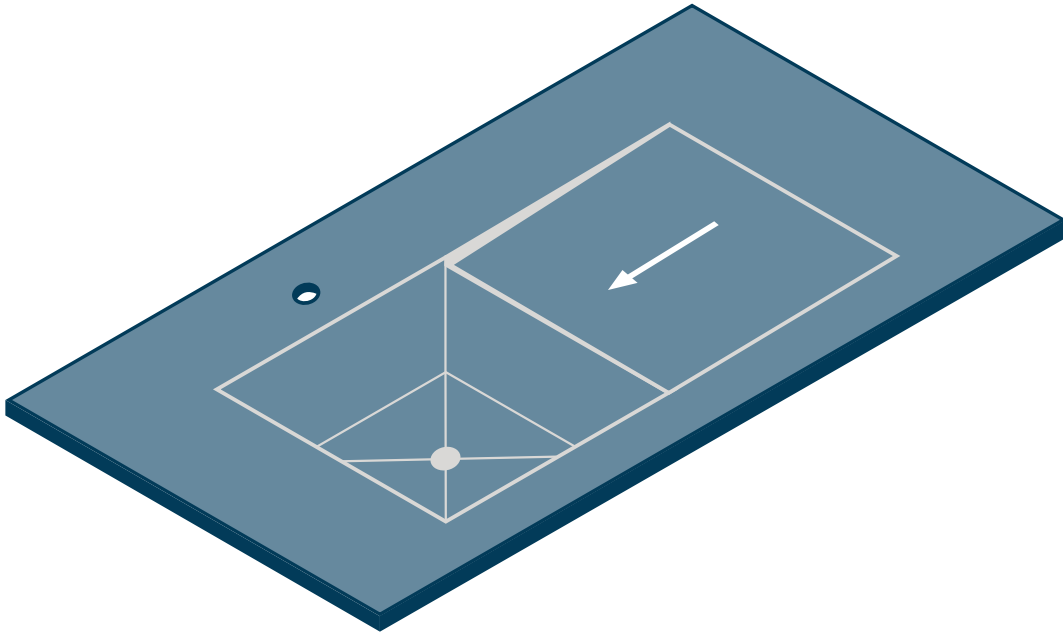

Making these components, which could require cutting 90° angles, as already specified in paragraph 5.2, must be done exclusively by companies with extensive experience in these processes. It is necessary to pay particular attention to the kitchen countertop and base units to guarantee the correct installation of the sink and the consequent resistance level.

5.6.3 Making a sink without a base pan

It is possible to make a sink by gluing together pieces of suitably shaped Laminam 12+ and 20+ slabs. This method usually does not include a containment tank in another material, and therefore must directly guarantee watertightness and water drainage, through the correct bonding and slope of the component portions.

5.6.4 Making a sink with a base pan

Another advisable method for making a sink in Laminam ceramic consists in cladding a base pan that is anchored to the countertop and has the right slope to guarantee water drainage.

Using a base pan guarantees further watertightness and functions as a support for the individual portions of shaped slab that form the sink.

This method makes it possible to make a sink with a readily serviceable drain, and therefore without having to be watertight. The base pan provides that function.

Pieces of Laminam 12 and 20 slabs of the same type used to make the countertop can be bonded to the base pan, but it is also possible to use slabs 5.6mm thick to reduce the weight of the sink.

In this case, the material will definitely be a different shade than the top and, given the reduced thickness, they guarantee less shock resistance.

The base pan can be made of different materials, built by the manufacturer or purchased on the market, such as for example, models in steel. The slab portions must be glued to the base pan with full spread of adhesive, without leaving empty parts, and using a glue that is suitable for the material.

5.6.5 Undertop integration of Laminam sink

In this type of installation, the sink basin is mounted under the top following the instructions given in paragraph 5.3.3, and therefore the edge of the top is visible in the sink. Even if the internal cladding of the basin is assembled at 90°, this solution allows tops to be made with radiused angles on the cutout, which guarantee greater resistance

5.6.6 Integration of Laminam sink at 45° with the countertop

This type of application involves the sides of the Laminam ceramic sink being joined at 45° angles with the kitchen countertop to ensure maximum continuity and the best aesthetic result.

This process requires cutting 90° angles, as specified in the previous paragraph 5.2, and must be undertaken only by specialized manufacturers that are able to guarantee the work, after having run all the tests deemed necessary.

The joint between the sink walls and the countertop should have a bevel of at least 2mm.

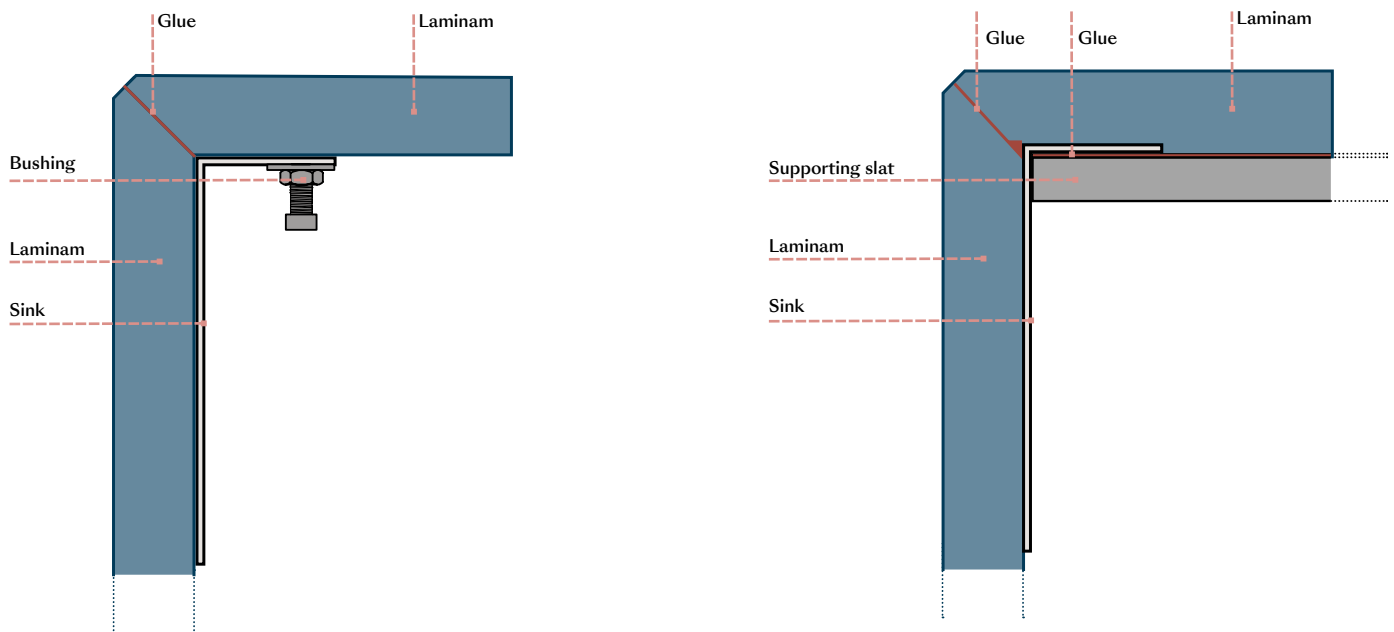

5.6.7 Anchoring and handling of integrated sinks

Sinks made with these methods are sometimes supplied by the manufacturer preassembled with the countertops. Other times, they are assembled when the kitchen is installed. Since they are quite heavy, in addition to reinforcing the perimeter of the cutout in the countertop, it is important to pay close attention to the supports placed underneath the sink, as described in the paragraph 5.3, to prevent the weight of the sink from being supported completely by the countertop. The sink can be anchored to the countertop with mechanical fixings and/or epoxy adhesives.

5.7 Verifying the base units and supports for the countertop

5.7.1 Kitchen and bathroom countertops

Since the counter is the top surface of the furniture that forms the base of the kitchen or the bathroom, it is fundamental that the design process include checking to make sure that the supports are suitable and sufficient in number to guarantee adequate support and resistance over time.

Surfaces made of Laminam 12+ and 20+ slabs can be supported by transversal bases without other supports, up to a maximum center distance of 1200mm.

When the countertop has cutouts for inserting sinks or hobs, reinforcements must be inserted between the transversal bases to support the weight of that portion of the top, while preventing it from being supported only by the perimeter parts of the holes. Cracking could result from failure to provide adequate support. Generally speaking, in kitchens with doors that open and disappear, a “groove” or “recess” is inserted under the top, along the entire front of the kitchen. This feature normally guarantees perfect levelling between the kitchen base units, and a reinforcement where there are cutouts on the countertop.

The cutouts for a sink and hob inserted into an island unit must also be supported along the entire perimeter.



The manufacturer can mount reinforcements underneath a countertop which is designed to set on base units that are very far apart, or which requires greater resistance for reasons linked to dimensions, logistics, or other factors.

These reinforcements will normally be made from slats obtained from Laminam 12+ or 20+ slabs (ideal because they have the same expansion coefficient as the countertop), with steel bars or panels in plywood or rigid foam. All reinforcements must be installed with glue/silicone products with suitable horizontal elasticity to compensate for possible expansion between the two products.

5.8 Creating protruding parts and overhangs with Laminam 12+ and 20+

Laminam 12+ and 20+ slabs have been tested with a precise static load of 100 kg applied at a distance of 50 mm from the external edge of the protruding part without using substrates. When there is a protruding part, pay particular attention to anchor the countertops to the bases, whether mechanically or using an adhesive, in order to prevent the lever effect from causing countertop movements that might produce crazing especially near the holes.

Given below are the maximum values of protruding parts suggested for Laminam 12+/20+ with unit width 600-3240 mm.

Laminam 12+ O max 350 mm

Laminam 20+ O max 450 mm

The part of the countertop placed on a protruding part must guarantee a depth free of holes that are at least equal to the protruding part, with the sole exception of the circular hole for taps.

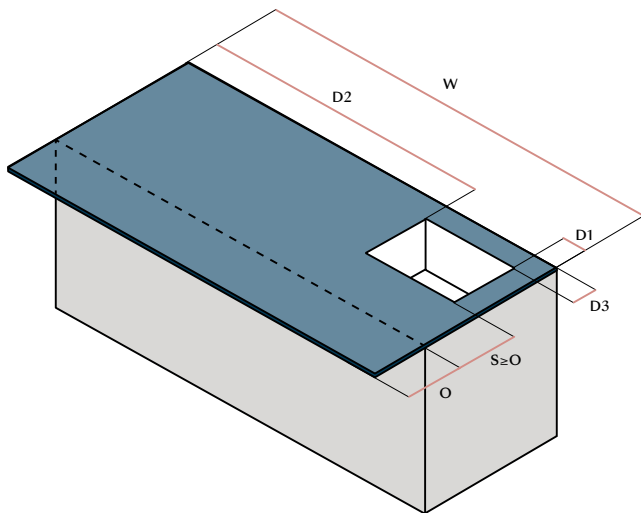

$W \geq 600 \text{ mm}$

O = Protruding wall

S = Area with substrate

$D1 \geq 100 \text{ mm}$

$D2 \geq 100 \text{ mm}$

$D3 \geq 100 \text{ mm}$

$D1 + D2 \geq O$

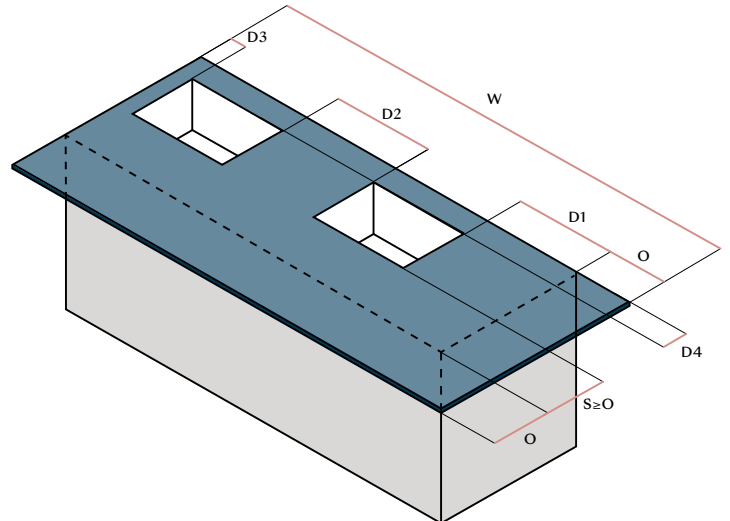

$W \geq 600 \text{ mm}$

O = Protruding wall

S = Area with substrate

$D1 \geq 600 \text{ mm}$

$D2 \geq 600 \text{ mm}$

$D3 \geq 100 \text{ mm}$

$D4 \geq 100 \text{ mm}$

To create a protruding part larger than the values specified above, or if the distance between the hole and the protruding part cannot at least correspond to that of the protruding part, the kitchen base requires a reinforcement with steel profiles and maximum span 1200 mm or a continuous wooden panel to ensure a stable countertop and prevent bending.

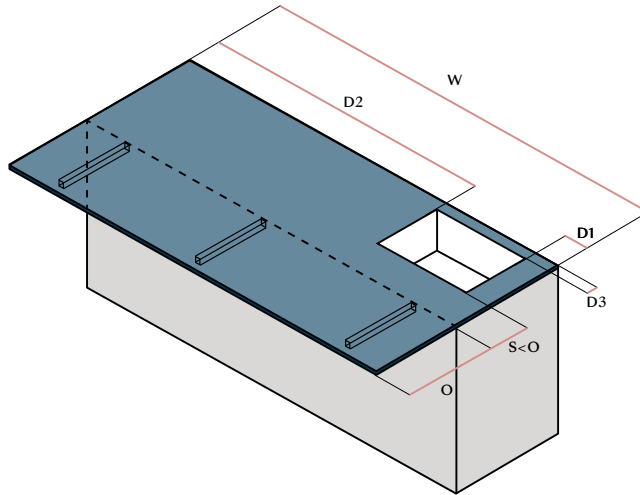

$W \geq 600 \text{ mm}$
$O = \text{Protruding wal}$
$S = \text{Area with substrate}$
$D1 \geq 100 \text{ mm}$
$D2 \geq 100 \text{ mm}$
$D3 \geq 50 \text{ mm}$
$D1+D2 \geq O$

5.9 Tables

To fix the Laminam 12+ or Laminam 20+ slab to the table frame, it is possible to use glass accessories, such as recessing anchoring, with an indicative maximum depth of 6 mm. Alternatively, depending on the table frame and the designated use, e.g. indoor or outdoor, it is also possible to use Velcro or adhesives (such as epoxy).

5.10 Top joints and extensions

In building projects, we suggest not to place slabs of the same finish and different thicknesses, which have different shades, side by side on the same floor.

For finishes that present non-uniform graphics and/or directions, verify the final effect of the parts by dry fitting the adjacent parts to verify final compatibility. Also verify that the pieces have uniform thickness and, if they do not, the lower part of the visible edge can be abraded to make them uniform.

When creating “L” shaped tabletops, it is advisable to fit the slabs using a straight pattern. When installing the top, fill the joint between the two slabs with silicone. If you are building a table with extensions, the leaves must be made from the same slab to provide continuity, so that the extensions have the same graphics and shade continuity.

This also allows you to create continuity between the tabletop and the extension leaves in case of small deviations that are still within tolerance limits.

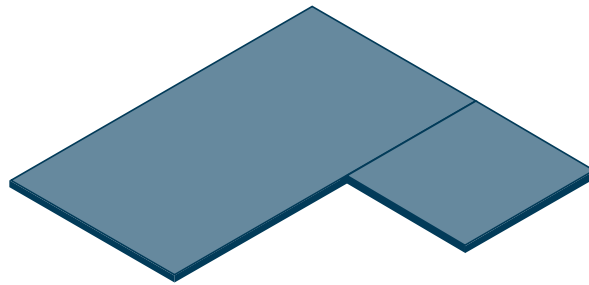

The configuration of the diagonal cut is possible only if the kitchen base unit guarantees support for the point where the diagonal cuts meet.

This type of configuration is used when graphic continuity is required, especially for veined slabs, and it is made from a single portion of slab or two slabs with a “book match” finish.

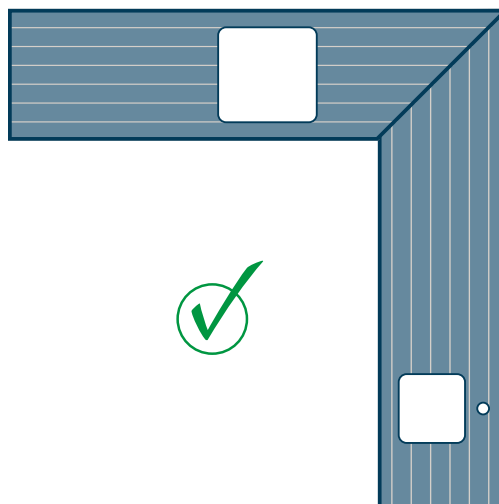

The design of “L” shaped surfaces made in a single piece is advisable only if the base units that will support the surfaces are perfectly plane, levelled and structurally solid and stable.

The pieces described above require very delicate handling. It is crucial to pay close attention during the handling, packaging and installation phases to avoid movements or twisting that could damage the surface and cause it to break.

The inside corner of single-piece L-shaped tops must have a minimum radius of 5 mm.

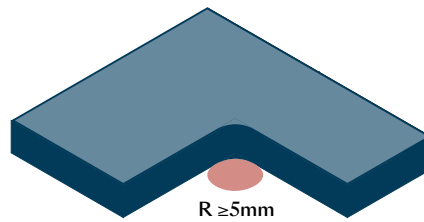

6 | Laminam processing



6.1 Processing Laminam 12+ and Laminam 20+ slabs

Laminam can be processed with machines for materials like natural and composite stone, marble and glass.

Before beginning a cut, verify the maintenance status of the machine you are planning to use, in particular:

- The worktop must be solid, resistant, clean and free from defects.
- The worktop must be perfectly planar and level.
- No irregularities must be present on the worktop, and it must be free from debris from previous jobs.
- The tool must be suitable for processing porcelain stoneware and in good condition.

The operating parameters, in the ranges indicated in this guide, are suggested by machinery and tool producers and operators in the sector after tests on our materials. However, these parameters are purely an indication and must be verified by each user on the basis of the tools that they have available, their individual experience and the type of finish that they want to obtain.

Therefore, we advise each operator to do preliminary tests on samples before making cuts or starting processing operations, in order to properly test and program the machine and tools that they have available. If the cut finish turns out to be unsatisfactory, or the operation causes the slab to break, the reason could be a wrong feed rate, wrong pressure during the operation, or wrong tool rotation speed. Other causes could be imperfect planarity of the supporting surface, subjecting the slab to movements or vibrations during operations, or an incorrect choice of a cutting disk or tool..

6.1.1 Orientation of slabs during processing

It is advisable to plan processing operations for countertops with cutouts and openings to be positioned in the central part of the Laminam 12+ and Laminam 20+ slab.

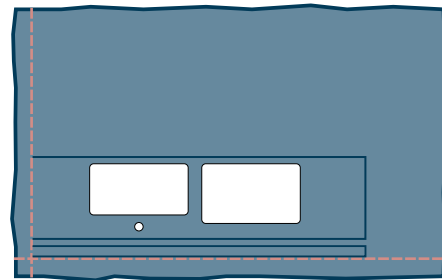
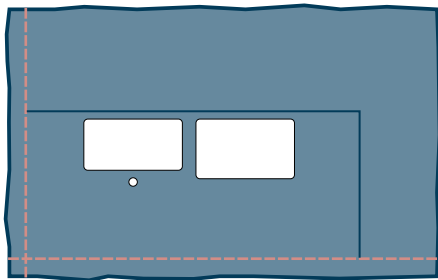
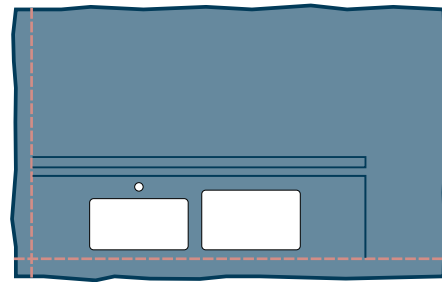
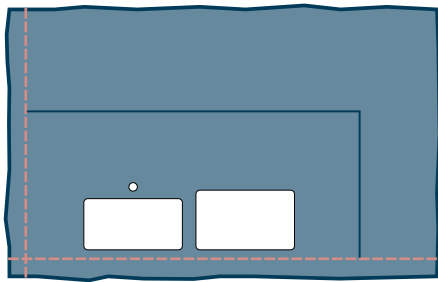

6.1.2 End of processing

At the end of each processing operation and before the piece is dry, thoroughly clean the surface with clean water.

For Laminam Lucidato finishes, it is necessary to clean the slab with compressed air to remove all dust residue. Given the characteristics of this type of surface, avoid contact or dragging with metal objects.

After finishing the work on any type of machine, it is very important to pay particular attention to how the slab is handled, in particular if there are openings or internal holes and cutouts. Use suction pad lifting equipment only if it is equipped with a sufficient number of pads, so that the slab will not bend in any way.

As an alternative, handle the slab manually in a vertical position and be very careful to avoid torsion.

6.2 Disc cutting

To cut the slab, use diamond cutting discs suitable for processing porcelain stoneware, which are in good condition, on industry approved machinery. Both segmented and non-segmented blades can be used.

The advancement of the slab in the cutting process must be in the same direction as the disk rotation. The cut takes place through the erosion of the width proportional to the width of the disk.

6.2.1 Cutting Scheme

Laminam “Full Size” slabs have untrimmed external edges. Start cutting by trimming the edges to make them square.

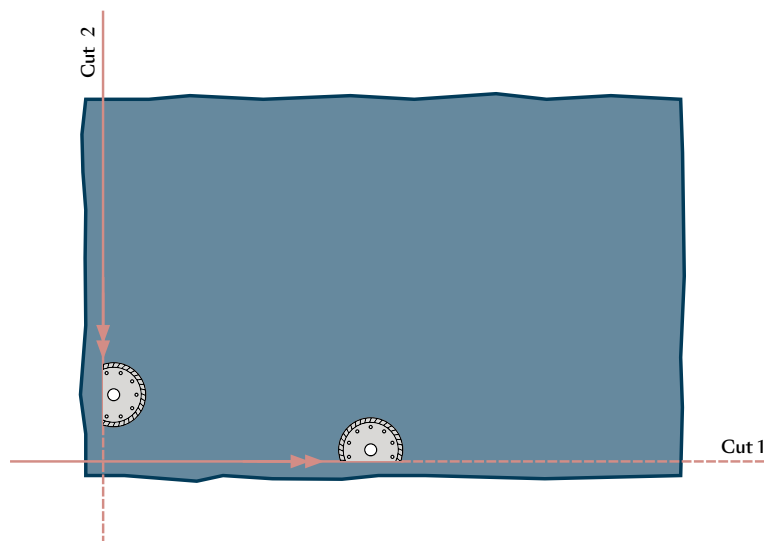

If you need to obtain a trimmed 1620x3240mm size from a “full size” 1620x3240mm slab, set the disk path to center this size at the center of the “full size” slab.

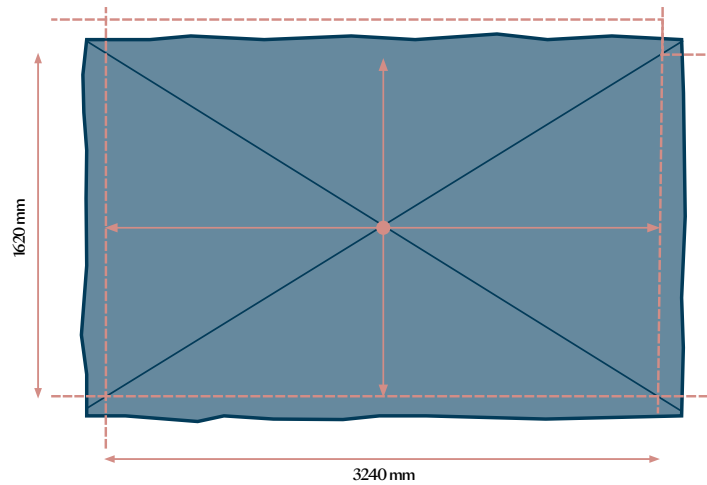

Here is an example of a cutting scheme that can be done with a disk cutting process.

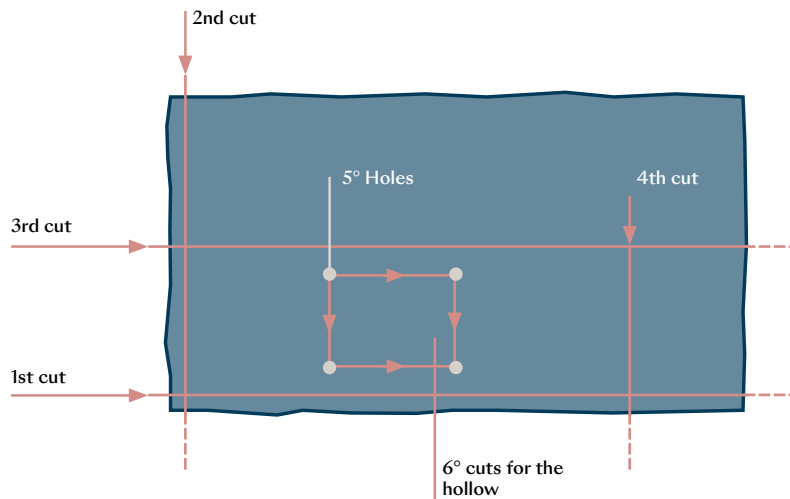

If you want to protect the piece of slab not being used to make the table or countertop, move the part above 4th cut before you start it.

If you want to protect the piece of slab not being used to make the table or countertop, move the part above 4th cut before you start it. If you are making “L” shaped cuts or cutouts with a disk, first it is necessary to make a hole in correspondence of each corner and then make straight cuts. The last part of the cut near the hole can be done manually with a grinder.

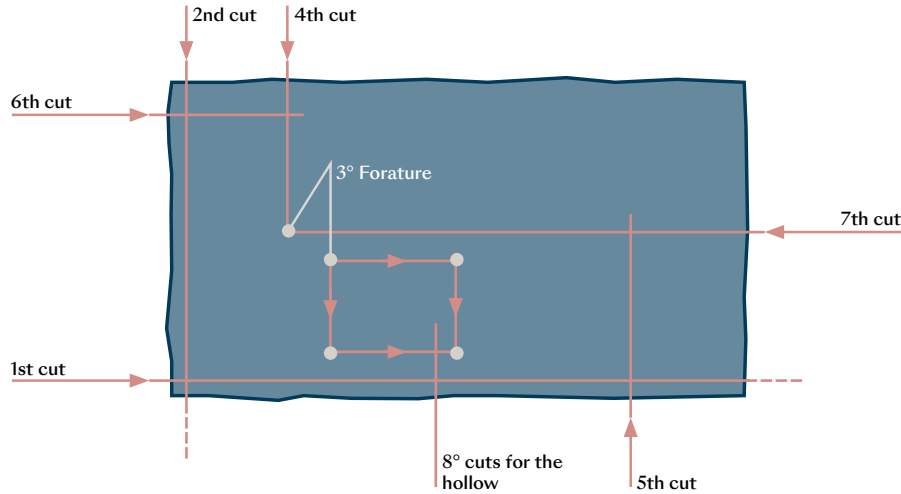

When performing cuts 5 and 6, the disk must go past the intersection of cuts 7 and 4, respectively, for a length of at least the diameter of the disk. “L” shaped pieces must be handled very carefully to prevent torsion and twisting that would damage the slab.

6.2.2 Indications

- Smaller disk diameters require greater rotation speeds applied to the mandrel.
- Slower feed rates produce higher quality cuts. Excessive speed could require making a larger bevel to correct imperfections caused on the edge.
- Cutting speed at the entry and exit points must always be reduced by 50% compared to full speed, for a length of at least the diameter of the disk.

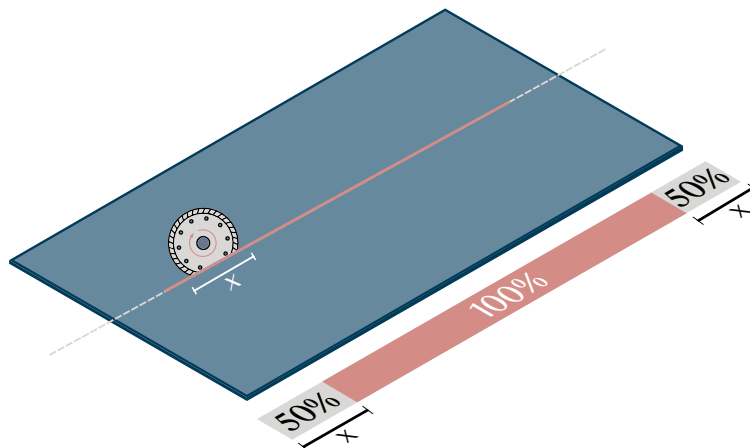

- Given the hardness and strength of the material, it is necessary to turn the nozzles so that the water jet is pointed on the disk blade to guarantee cooling and in correspondence with the incision on the slab to remove debris from the cut.
- The disk must cut completely through the slab thickness and come out at least 1 mm on the other side.
- The process is successful if vibrations and movements of the slab are reduced to a minimum during the cutting processes. To limit these situations, we advise using a panel made of rubber or other suitable material that will not reduce the abrasive capacity of the disk.
- Set the machine correctly to obtain inclined cuts in the slab.
- To make a good quality inclined cut, we suggest reducing the disk diameter and using a disk with a reinforced core that can diminish bending of the disk and therefore reduce vibrations on the slab. As an alternative, apply a flange and counter flange to stabilize a disk that is too big.

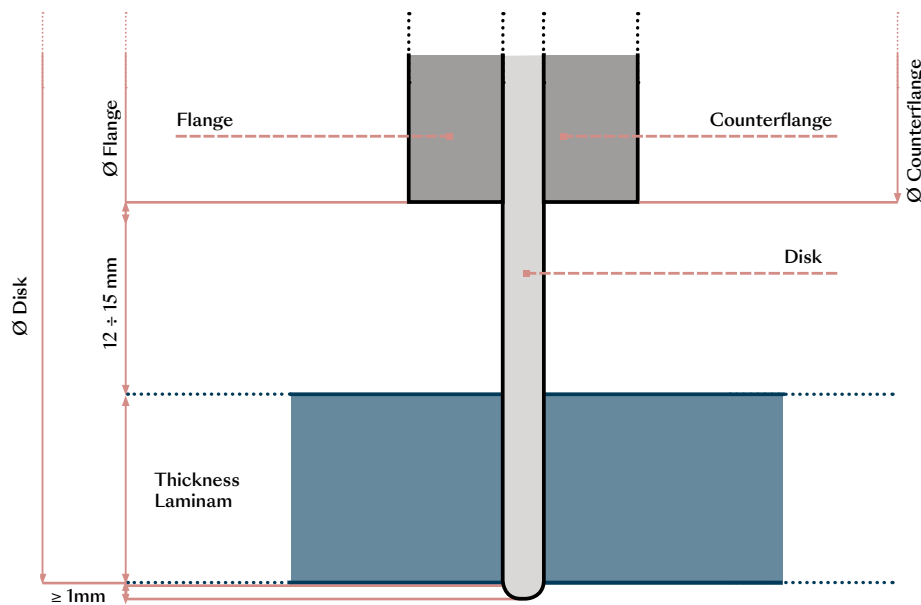

6.2.3 Parameters

The parameters indicated below were suggested by the main producers of cutting disks which have tested Laminam slabs, considering that the cut be made in a single stroke with a disk in good condition.

To obtain these parameters, tests were run on products with white, medium and black bases.

If the manufacturer, under his/her own responsibility, wants to adopt faster speeds than those indicated, we suggest carrying out several preliminary tests while keeping in mind that materials with a white base are generally more sensitive to increased speeds.

Periodically, assess the maintenance levels of the disk and replace it when it no longer guarantees a good quality cut, with reference to the parameters indicated. To guarantee longer disk life and better cutting quality, we suggest reviving the blade with a block of concrete or quartz.

Disk Cutting	Type of Cut	Disk Diameter mm	Rpm	Feed rate Mm / min	Infeed/outfeed speed
Laminam 12 +	Straight	350	1800/1900	1000/1400	Reduce by 50%
		400	1600/1800	1000/1400	
500		1300/1400	1000/1400		
Laminam 12 +	Inclined	350	1800/1900	500/800	Reduce by 50%
		400	1600/1800	500/800	
500		1300/1400	500/800		
Laminam 20 +	Straight	350	1800/1900	800/1000	Reduce by 50%
		400	1600/1800	800/1000	
500		1300/1400	800/1000		
Laminam 20 +	Inclined	350	1800/1900	400/500	Reduce by 50%
		400	1600/1800	400/500	
500		1300/1400	400/500		

6.3 Water-jet Processing

Laminam slabs can be cut with water-jet machines. This method makes it possible to perform any type of cutting, shaping and drilling or making holes, with a high level of precision.

We advise making sure that the metal support grid is in good condition and planar, and that the piece is correctly blocked to prevent movements that could make it impossible to cut the slab. If the machine allows it, it is also possible to make 45° cuts. Adjust the processing parameters to obtain a straighter or rounder edge. Begin by cutting the larger cutouts and then do the smaller ones (for example, first cut the hole for the sink and then cut the hole for the tapware). We suggest starting and finishing the cut off the slab.

6.3.1 Cutting Scheme

Laminam “Full Size” slabs have untrimmed external edges. Start cutting by trimming the edges to make them square.

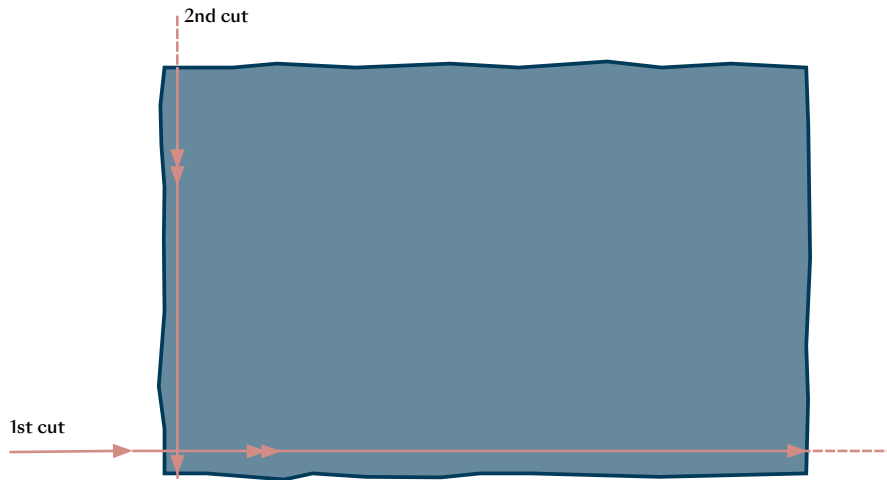

If you need to obtain a trimmed 1620x3240mm size from a “full size” 1620X3240mm slab, set the water-jet path to centre this size at the centre of the “full size” slab.

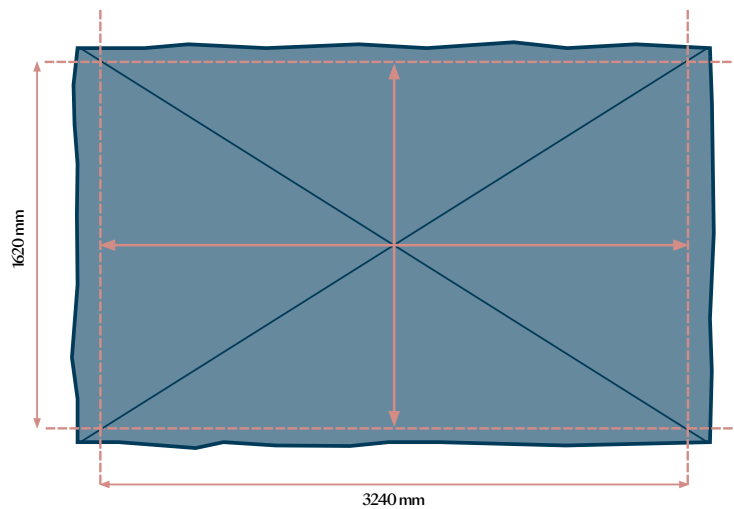

Here is an example of a cutting scheme that can be done with a water-jet process.

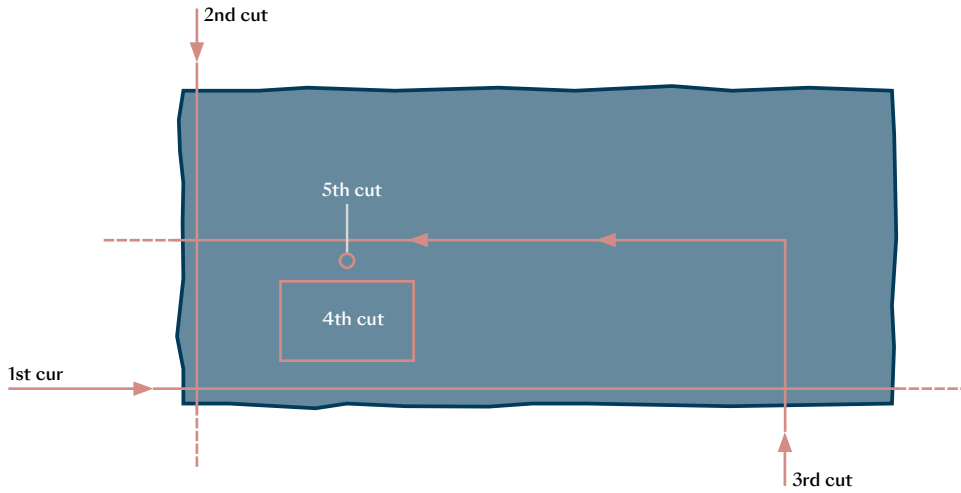

Here is an example of an “L” shaped cut that can be done with a water-jet process.

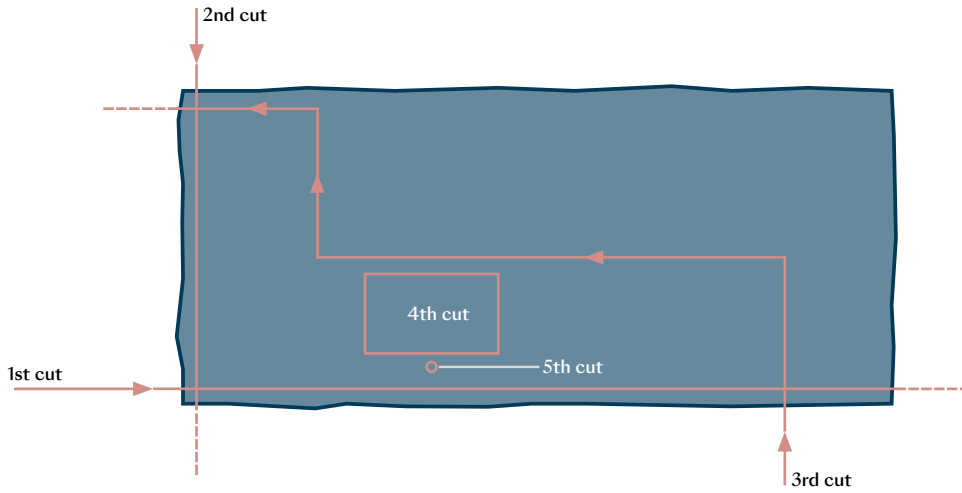

To make cutouts inside the slab, we advise starting the cut in a point that is inside the cutout area, and then gradually moving closer to the cut perimeter. Maintain the suggested minimum radius of 5 mm for internal corners.

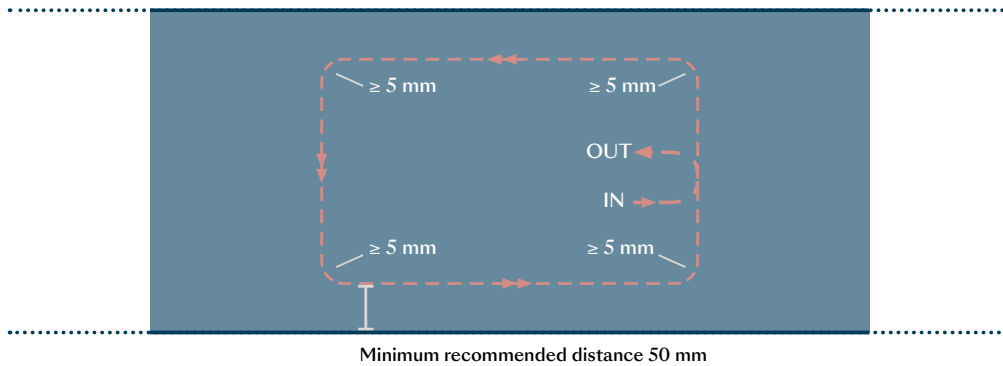

6.3.2 Parameters

Water-jet	Pressure (Mpa)	Feed rate Mm / min	Cutting Abrasive	Initial Drilling Pressure	Drilling Abrasive
Laminam 12 +	380/413,5	1000/1200	Mesh 80 (350/500 g/Min.)	40/80	Mesh 80 (100/150 g/min.)
Laminam 20 +	380/413,5	600/800	Mesh 80 (350/500 g/Min.)	40/80	Mesh 80 (100/150 g/min.)

6.4 Numerical Control Processing

Laminam slabs can be cut with numerical control machines (CNC).

The most complex CNC machines offer the option of rotating and inclining the cutting head for many types of cuts.

Normally, CNC is used after shaping the top with a disk or water-jet cutter. This machine is used primarily to create cutouts for hobs and sinks, and to finish edges for flush tops, holes, edges and curved lines as well as wall scribing.

The tool must be diamond tipped and suitable for processing porcelain stoneware. The choice of tool depends on the specific process to complete. Do not make cuts or holes when the tool is oscillating.

During the work, it is important to use plenty of water aimed in the right direction, both inside and outside the tool. The tool must be at least 1 mm wider than the thickness of the slab.

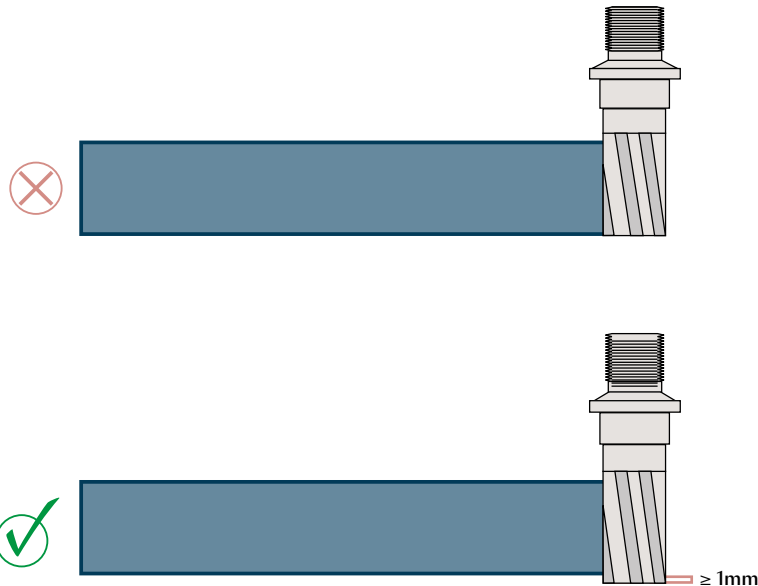

6.4.1 Positioning Suction Pads

Before beginning the process, check the correct hold of the suction pads on the back of the slab. If the hold is not satisfactory, use softer gaskets of the right thickness.

Correct positioning of the suction pads that hold the slab is a fundamental aspect of getting a good cut. For this reason, distribute the suction pads in a regular pattern to support the slab, including the part that must be removed. If you fail to do this, the part that is cut out could bend and cause crazing before the process is finished.

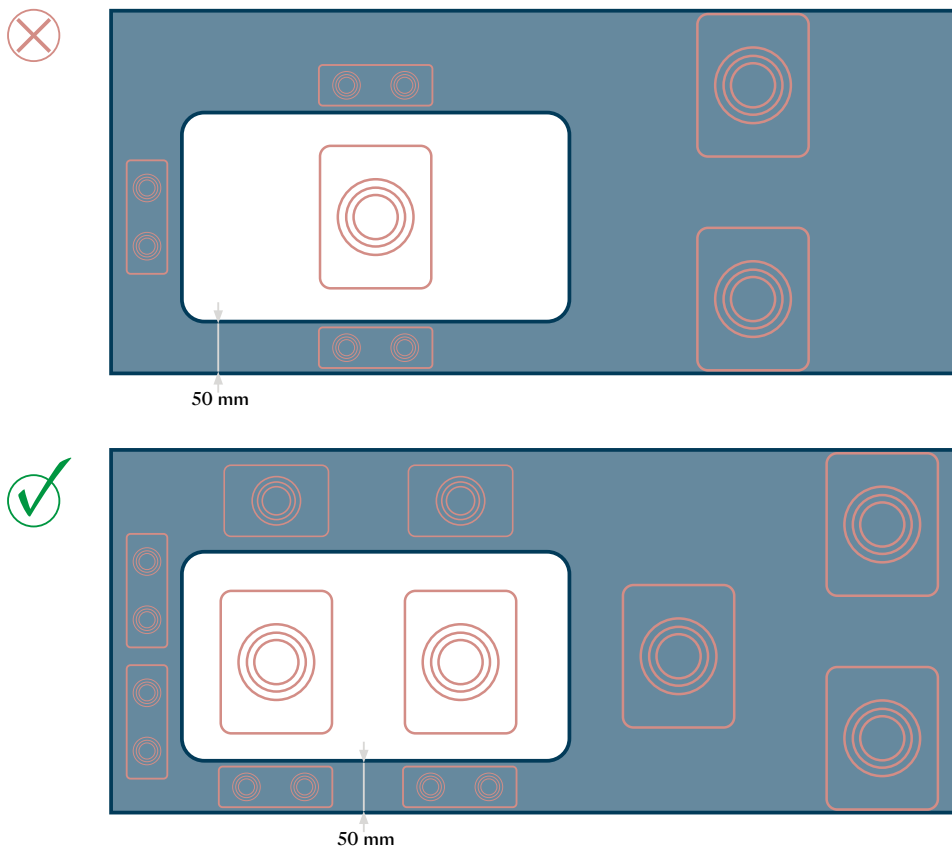

As an alternative to the suction pads, it is possible to use specific clamps: in this case, it is necessary to remember that the side with the clamp cannot be cut.

6.4.2 Flush Top Processing

Perform the cuts as shown in the scheme below without entering the perimeter of the 90° hole, which would compromise the quality of the final process.

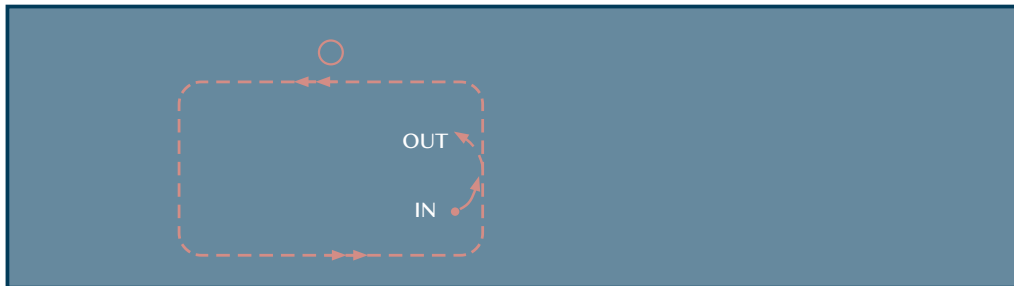
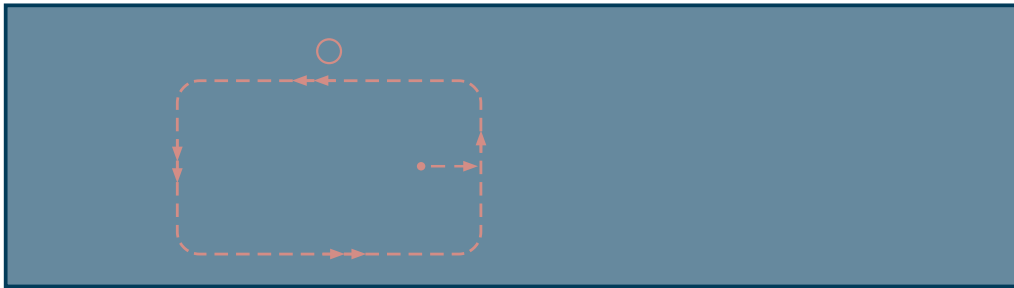

6.4.3 Flush Top Processing

We advise finishing the flush top before making the cutout.

It is possible to cut a maximum recess of 4 mm in a Laminam 12+ slab and 8 mm in a Laminam 20+ slab, of a suitable size and depth according to the instructions on the technical sheet of the sink or appliance to install.

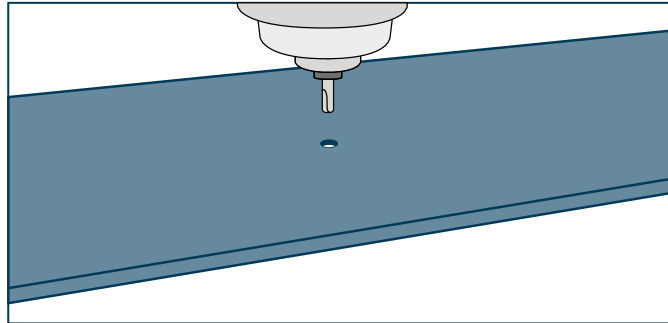

Drilling

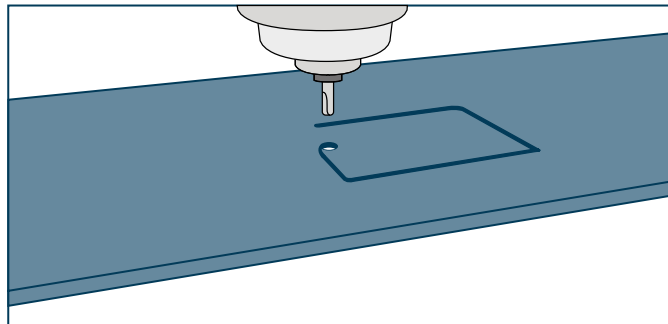

Incremental cutting

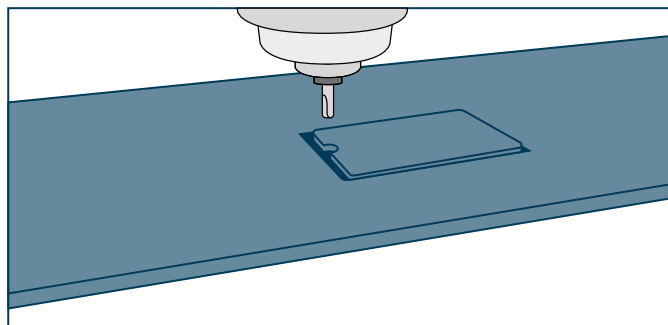

Cut

6.4.5 Cutting Parameters

CNC		RPM	Feed rate mm/min
Laminam 12+	Initial Hole	1800/3000	20/30
	Cutting Tool	3500/5500	200/300
	Flush Top	5000/8000	150/300
	Bevel	5000/6000	1500/2500
	Edge Polishing	3000/5000	1000/2500
Laminam 20+	Initial Hole	1800/3000	20/30
	Cutting Tool	3500/5500	150/200
	Flush Top	5000/8000	150/300
	Bevel	5000/6000	1000/1500
	Edge Polishing	3000/5000	1000/2500

6.6 Manual Processing

It is possible to use a manual cutting tool to perform cuts on Laminam 12+ and 20+ slabs.

Through the use of accessories such as disks, diamond drill bits or abrasive pads with different grades, it is possible to obtain cuts, holes or finishes of edges or details of the countertop surfaces.

It is important to position the slab being processed in a suitable position to avoid movements and vibrations. The area being processed should be bathed with water constantly or frequently, and the tool also, in order to guarantee correct cooling and the quality of the process.

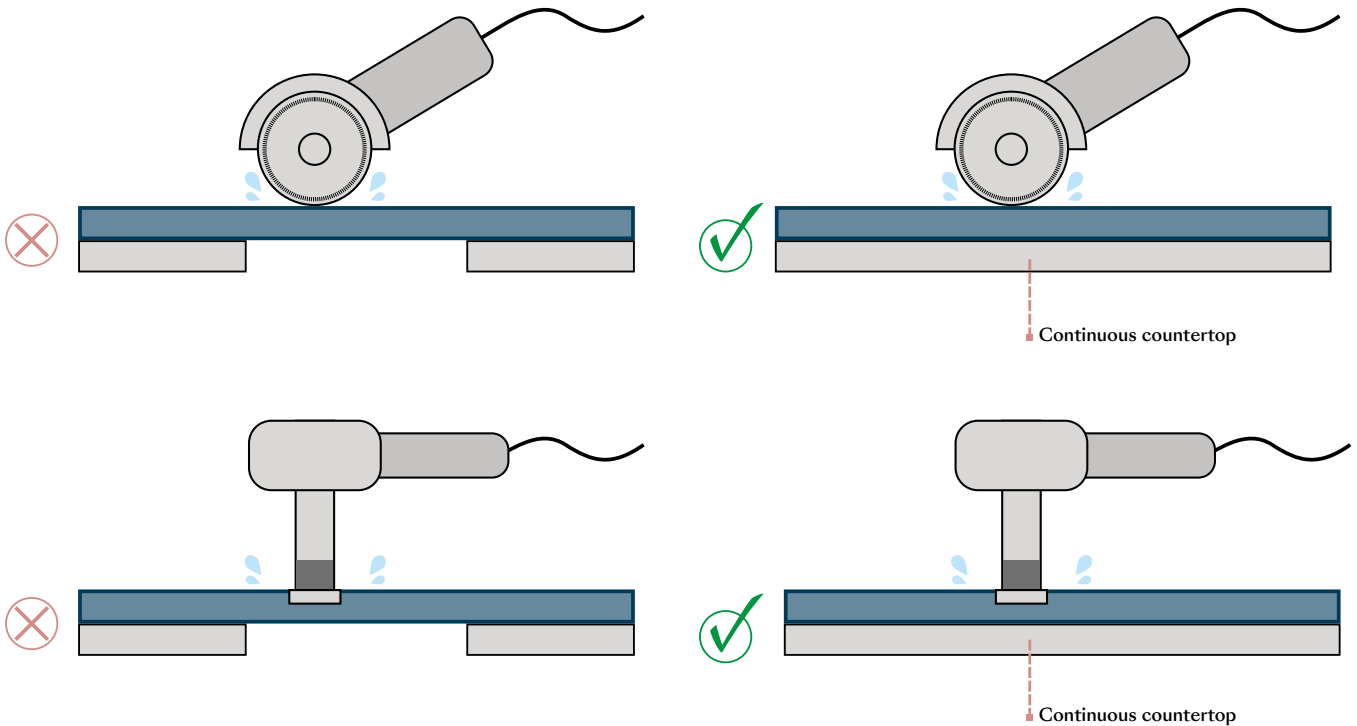

6.7 Cleaning after processing

Cutting, drilling and similar operations generate dust residue due to abrasion of the material. This residue, along with the water required during the processing phases, tends to become solid on the surface when it dries.

It is, therefore, vital to ensure correct cleaning at the end of the processing phases because, if this is done wrongly or inaccurately, it could cause smears that are difficult to remove (particularly visible on dark colors). Clean off the processing residue from the surface of the slab with plenty of water, then dry with a paper towel and repeat the procedure until the surface is clean. Do not store any machine-processed material when wet. During assembly of the kitchen countertop, polyurethane or epoxy adhesives are used for panels, integrated sinks. etc.

Epoxy products are designed not to be removable to ensure good performance over time. For this reason, they can stick to surfaces without being absorbed, but this makes them difficult or impossible to remove. It is, therefore, vital to remove them quickly by using soft sponges or cloths and cleaning products recommended by the suppliers.

Do not contaminate the rest of the surface with the cloths/sponges used to remove these materials. Do not move the finished surface with gloves that have adhesive products on them.

If any epoxy/polyurethane material is observed after installation of the countertop, they must be treated with basic products and soft sponges, but since they will have been completely hardened at that point, it might not always be possible to remove them.

7 | Edges



The edge finish can be obtained through processes on automatic machines (such as side polishers, numerical control machines) or by hand, depending on the desired effect.

7.1 Straight Edges and Bevels

The straight edge is the finish that makes it possible to display the edge of the Laminam 12+ and Laminam 20+ slabs. It is normally done as a perimeter border for the surface of kitchen table tops and countertops, or as a finish for a hole when the basin is applied under the top.

At a later time, if requested, it is possible to polish the edge with a sequence of increasingly fine abrasive diamond wheels on CNC machines.

We suggest making a beveled edge of at least 2 mm to increase the strength of the edge in case of accidental impact. For beveling of curved lines, it is necessary to use a CNC machine with a grinding wheel on 5 axes.



7.2 Other types of edges

Other types of edges (such as bullnose and half bullnose) can be obtained with specific profiling grinders used on CNC machines.

Therefore, many different edge finishes can be obtained by using different grinders. The working speed must be tested in advance.

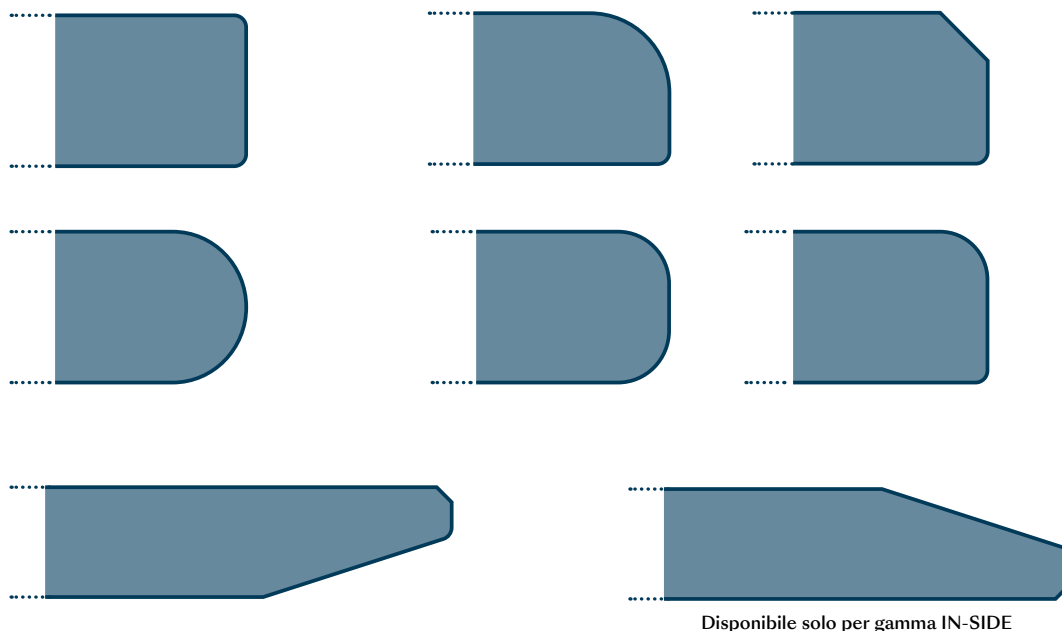

7.3 Edges and Box Structures

It is possible to process Laminam 12+ and Laminam 20+ slabs to obtain continuous joints for making panels of heights taller than the thickness of the product, basins and box structures.

This solution is also adopted when graphic continuity is desired on the front panel of the top.

After creating the portions to glue, we advise protecting the adjacent surfaces with plastic film or rubberized tape to prevent you from getting glue on the slab, because the adhesives will be hard to remove after they harden.

Clean the portions to glue and apply a homogeneous layer of glue to the entire surface. Make sure that the portions are kept in position until the glue dries completely, in compliance with the manufacturer's instructions. After the glue hardens completely, make a bevel of at least 2 mm.

Sequence of steps with 5-axis disc cutter

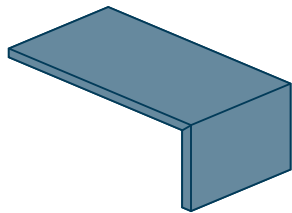
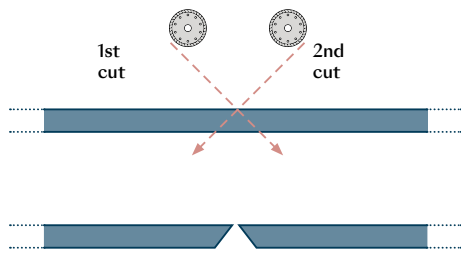

Sequence of steps with 5-axis water-jet cutter

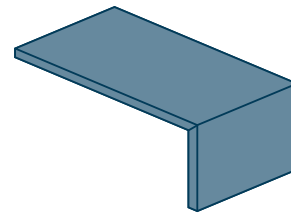
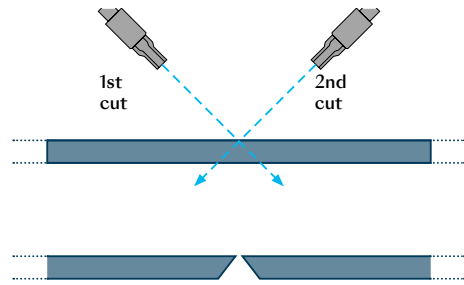

We suggest reinforcing the joint by applying slats made from unused parts of the Laminam slabs, fixed with the same type of adhesive used to glue the 45° angle.

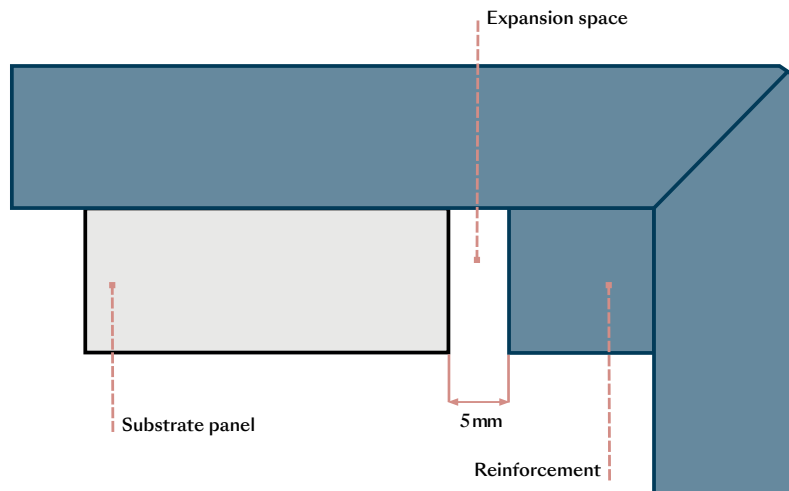

We suggest using two-component adhesives, generally epoxy based or equivalent, which can be purchased freely. These adhesives can be pre-colored or transparent, and specific-colored additives can be added.

Below is a selection of products available on the market. Different companies have colored glue or adhesive products in their range which can be matched Laminam finishes. Please ask the producer directly for suitable products.

	Adhesive for gluing Laminam 12+ and Laminam 20+ slabs	Correspondence between adhesive colours and Laminam finish and Adhesive Technical Sheet
Akemi	Colour Bond (internal use) Akepox 5010 (internal use) Coloured cartridges	www.akemi.de/en/
Tenax	Powerbond	On demand www.tenaxceramica.it
Integra Adhesives	Integra Xi Coloured cartridges Integra Ultra (external use)	www.integra-adhesives.com

We recommend proper and immediate cleaning of all glue and adhesives used, in compliance with instructions from their producers. Removal after the glue has hardened could prove to be impossible and would cause halos to form on the slab over time.

7.4 IN-SIDE Edge Finish

To finish Laminam Fiammato products made with IN-SIDE technology, it is possible to recreate the surface structure on the edges of the slab.

This operation is usually done by using a sanding machine, commonly used for natural stone, with the right level of air pressure and quantity of sand.

We recommend protecting the horizontal surface of the slab so that it is not affected by the sanding process, which would compromise its finish and technical characteristics.

7.5 Fibre Abrasion

It is possible to remove the fiber reinforcement on the visible portion of the countertop edge either manually or using cutters to improve aesthetics. Since this material is fiberglass, applied with a polyurethane adhesive, it is necessary to carry out this operation under current national safety regulations.

8 | Bonding laminam on other materials



Laminam slabs in the thicknesses 12 and 20 mm do not generally require reinforcement with other materials. There can be a need to bond the slabs mainly if there is a perimeter panel, in order to create a filler and a uniform horizontal surface.

We suggest using materials with expansion coefficients similar to Laminam slabs, such as polyurethane foam suitable to hold the fixings necessary for the countertop.

These materials can be applied with epoxy-based, polyurethane or MS polymer adhesives, also in points and not full spread.

If it is necessary to bond the top to create a reinforcement, for example if it has a particular design, an absence of suitable supports on the kitchen base units or excessive protrusions, the support material must be glued with a full spread application and can also be constituted by tubular steel/aluminum.

In this case, use extremely elastic adhesives and be careful to avoid reinforcements near cooking areas, which could cause excessive expansion.

The choice of gluing material, the glue to use and the frequency of application are all at the discretion and under the responsibility of the installer, and must be verified based on the conformity of the countertop, the materials used and the intended use of the countertop.

9 | Transport and installation of the finished countertop



During handling, transport and installation of the finished countertop, remember to pay the utmost attention to possible twisting, torsion or impacts, in particular on the edges. Reviewing jobsite access with installers can assist in comfortable and efficient installation.

9.1 Packaging and transport

After finishing the processing, move the finished top into a vertical position and keep any holes towards the top. Never use the holes as lifting points, especially during transport, to prevent cracks or breakage.

We advise packing the countertop inside wooden crates or suitable frames and taking care that the edges and corners are protected with foam or polystyrene guards.

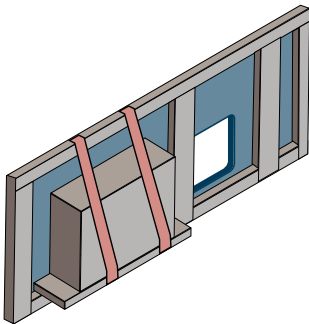
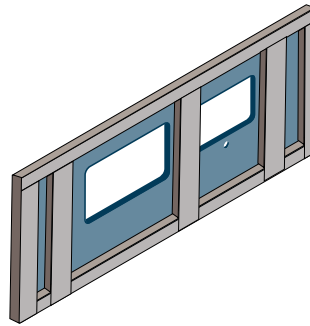
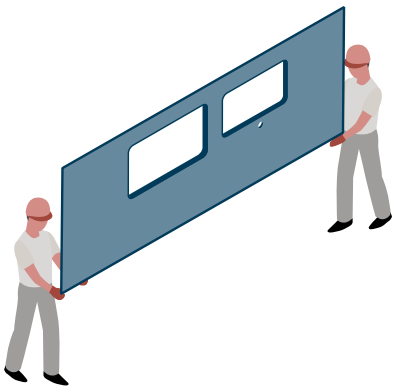

If the top has a preassembled basin, it must be encased in a wooden crate with a support that can sustain the weight of the sink, so that it does not cause the top to twist.

9.2 Installation

Verify that the kitchen base units are perfectly level and fastened together. This condition is necessary because the top must be supported continuously by the kitchen base units. Where the base units cannot guarantee perimeter support, it will be necessary to insert suitably dimensioned supports of adequate materials between the bases to support the weight of the top. This reinforcement must apply also if there are 45° joints between two portions of the top. After removing the packing, keep the countertop in a vertical position at all times when handling, and keep all holes towards upwards. To limit breaking during assembly, we suggest moving the top to the place where it is to be supported on the base units or vertical profiles while supporting the lower part with a wooden panel. Pay particular attention if the top has an integrated sink at the moment when it is placed in a horizontal position to be positioned on the kitchen base units. The weight of the sink basin must always be supported until the top is perfectly installed. Take care that the kitchen base units are fitted with their proper perimeter supports, as designed, and that sink basin supports are positioned immediately (see paragraph 5.3).

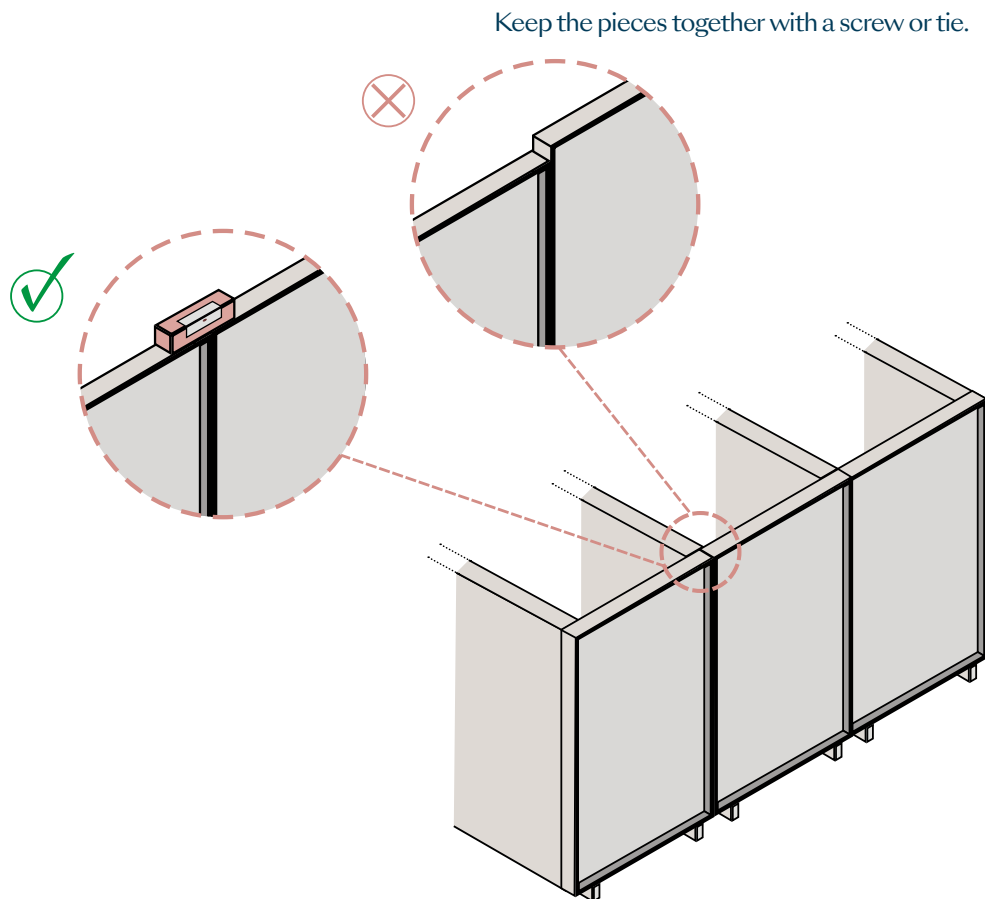

If the base unit has sliding drawers, these supports must be suitably shaped to allow them to slide properly. In cases of countertops with particular shapes or types of kitchens/ base units that do not guarantee adequate support, it is possible to position a surface generally in wood, or wood-based material, that guarantees constant uniform support for the countertop. We advise installing the surface at a distance from the wall of 2-3 mm and filling the gap with silicone, being careful to distribute it uniformly.

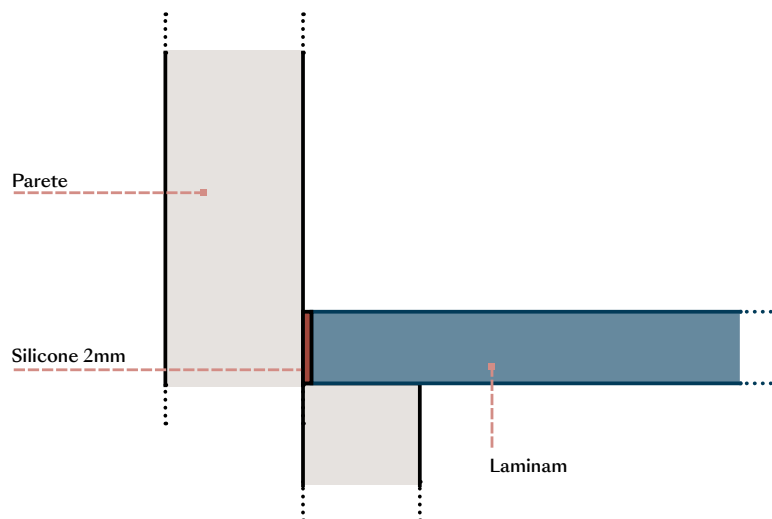

Protect the surface next to the silicone application with plastic film or rubberized tape. For tops made of more than one piece, place the portions carefully to prevent mistakes with visible edges. It is possible to facilitate this operation by inserting thicknesses which must be removed with the slabs positioned.

Join the two portions together using silicone products or transparent or colored glues, and then cleaning up the residue immediately afterwards.

When mounting the sink, it is necessary to seal the edge with silicone, an adhesive gasket or another equivalent product to guarantee watertightness and avoid the accumulation of dirt. Based on the type of sink to install, use a fixing system that is envisaged or designed by the manufacturer which is consistent with the mechanical fixing and/or adhesive.

Prepare two support bars or other equivalent systems to support sink basins, to be fastened to the furniture structure, so that the weight of the sink basins and the water that they contain is not supported exclusively by the top. Hobs must be installed in a centered position with respect to the prepared hole. Verify that the perimeter expansion space is maintained, as described in paragraph 5.3.

9.3 Cleaning after installation

Remove any silicone residue used for installation and sealing of appliances by using diluent products and soft sponges. Use acidic products and soft sponges to remove any cement-based residue left by back panel processing.

Then, before first using the countertop, sanitize it by initially cleaning with an alkaline cleaning agent for ca. 5-10 minutes. Proceed by wiping with a non-abrasive soft sponge, rinse with abundant water and dry the surface with a microfibre cloth. This operation contributes to remove any organic residue present on the surfaces following production, transformation and installation of the countertop.

10 | Cleaning, use and maintenance



The natural origin and production process make Laminam slabs almost entirely devoid of surface porosity; hence, they are easy to clean and suitable for use as kitchen countertops and table surfaces.

The same process ensures product hardness and compactness. During daily use, avoid any impact that might especially scratch the most delicate areas of the countertop, such as corners, edges, integrated sinks, etc. Do not use the countertop incorrectly. Avoid loading it with heavy weights, such as by climbing on it, as this might cause breakage particularly in processed areas, such as sinks and stoves, or in areas lightly supported by an underlying structure.

To clean Laminam surfaces, use a microfibre cloth or soft sponges and hot water; if necessary, use neutral detergents commonly sold to clean kitchen surfaces and appliances. When correctly maintained, the Laminam countertop will not require extraordinary cleaning. Please note that, generally, a quick intervention makes it easier to remove stains. If left to settle on surfaces for a long time, some residue might require the use of a specific cleaning product.

The choice of detergent will depend on the type of residue; for food stains, use alkaline detergents (products with high pH, such as ammonia or bleach); for inorganic stains, use acidic detergents (e.g., anti-scale); and for oily stains use degreasing products.

After using detergents, rinse the countertop to avoid the formation of smears or patinas on the surface.

Stain	Daily cleaning	Detergent for stubborn residues
Wine	Warm water and a neutral detergent	Alkali*
Icecream, Coffee, Tea, Tomato, Balsamicvinegar, Lemon, Cocacola, Beer, Fruitjuice, Jam, Milk, Nicotine	Warm water and a neutral detergent	Alkali*
Oil, Butter, Grease and oily substances, Wax	Warm water and a neutral detergent	Degreasing
Rust, Limescale, Metallic marks, Cement residue, Chalk	Warm water and a neutral detergent	Acid
Nail varnish	Warm water and a neutral detergent	Solvent

*If bleach (alkaline cleaning agent) is used, dampen a soft cloth and rub the surface for a few seconds. Most of the residue will disappear 2-3 minutes after application. Alternatively, pour it directly onto the surface. Leave it to work for a maximum of 10 minutes on shiny surfaces, making sure that it does not dry. Repeat the procedure until it is completely clean, rinsing after each application.

Prescriptions

- Do not use fluorhydric acid or products containing it.
- Do not use abrasive sponges or metal wool.
- Always avoid cleaning agents containing abrasive particles on the Lucidate (polished)/Soft Touch surfaces.
- To remove stubborn stains, when using mildly abrasive products that cannot, however, be used on Lucidate (polished)/Soft Touch surfaces, ensure that the pressure applied does not have a polishing effect on the treated area.
- Do not use products that contain wax or polishes.
- When they are not promptly removed, staining agents might leave stains that are not entirely removable on the Lucidate (polished) surfaces.
- Metal objects, such as cutlery, saucepans and knives, might cause surface scratches on Lucidate (polished)/Soft Touch surfaces. Use trivets and cutting boards when preparing food.
- Avoid dragging/using objects with a hardness equal to or greater than ceramic on all surfaces as this could cause permanent scratches (e.g. ceramic knives, diamond tools, etc...).
- Laminam surfaces, with the exception of the Lucidate (polished)/Soft Touch ones, do not fear scratches caused by metal objects and cutlery. Having a lower degree of hardness, in case of rubbing, they might leave metal residue on the countertop. Such residue, which shall not be considered surface defects, might be hard to completely remove. They might be more evident on products with a black background.
- Avoid direct contact with the flame.

11 | Safety information



Handling, storage, installation and other phases that do not involve transforming or processing the slabs do not pose any risk of inhalation/breathing of respirable particles, fibres or dust.

When Laminam slabs are being transformed, crystalline silica and glass fibres are released into the air. To prevent occupational diseases, such as silicosis and lung diseases, the worker who carries out processes which can produce this type of dust must adopt preventive and protective safety measures in conformity with local safety and hygiene regulations to contain the risk.

These measures can be collective (for example, localized ventilation or extraction systems for capturing diffused dust) and individual (for example, FFP3 filtering face masks).

For more information, please refer to good practices and the Safety Information Sheet for Laminam slabs, which can be downloaded in the reserved area of the website Laminam.com.

12 | Liability disclaimer



This guide contains information about all design, processing and installation phases of Laminam slabs to obtain kitchen countertops. Taking into account the high craftsmanship standards, please note that the information provides a rough indication and must be verified prior to implementation by the client or by the person appointed to implement the transformation.

In case of doubt or for clarifications, please visit the website www.laminam.com or contact Laminam SPA.

Technical Partners:

• Machines

1. INTERMAC – BIESSE SPA
2. DENVER SPA
3. PRUSSIANI ENGINEERING SPA

• Tools and disks

1. ADI SPA
2. TYROLIT VINCENT SPA
3. DIAMUT – BIESSE SPA
4. TECNODIAMANT SRL
5. MARMOELETTROMECCANICA SRL
6. ITALDIAMANT SPA
7. DIATEX

• Adhesives and finishing products

1. TENAX SPA
2. INTEGRA ADHESIVE INC
3. AKEMI GmbH

• Prodotti detergenti

1. FILA SOLUTION
2. FABERCHIMICA
3. BONASYSTEM

Consult our website www.laminam.com for the most recent versions of this document and of the Technical Sheets.

13 | References









Laminam12+
1620x3240

Indoor
Calce, Bianco





Laminam12+
1620x3240

Private house by
Cameo Kitchens & Fine Cabinetry
I Naturali,
Bianco Statuario Venato Soft Touch

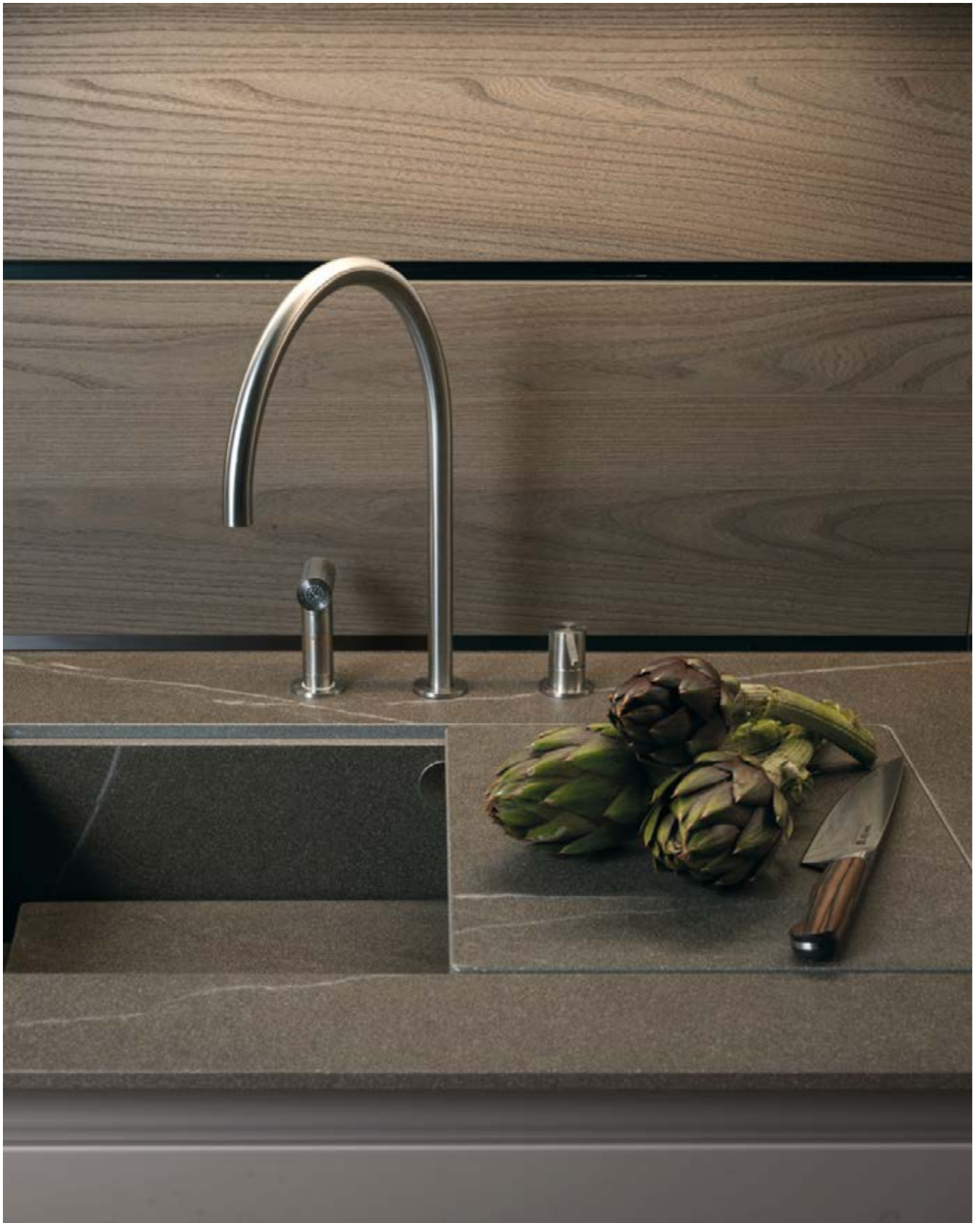



Laminam 12+
1620x3240mm

Euromobil
design: Roberto Gobbo
ANTIS / TELERO

In-Side, Pietra Piasentina Taupe



Laminam12+
1620x3240mm

Outdoor
Calce, Bianco





Laminam20+
1620x3240mm

Kitchen |
Milan/Italy

IN-SIDE, Pietra di Cardoso Nero Naturale
IN-SIDE, Pietra di Cardoso Nero Fiammato





Laminam Headquarters

LAMINAM S.P.A.
VIA GHIAROLA NUOVA, 258
41042, FIORANO MODENESE
MODENA / ITALY
TEL +39 0536 1844200
INFO@LAMINAM.COM
WWW.LAMINAM.COM

Production Plants

LAMINAM S.P.A.
VIA GHIAROLA NUOVA, 258
41042, FIORANO MODENESE
MODENA / ITALY
TEL +39 0536 1844200

LAMINAM S.P.A.
VIA PRIMO BRINDANI, 1
43043, BORGO VAL DI TARO
PARMA / ITALY
TEL +39 0525 97864

Showrooms

LAMINAM S.P.A.
VIA GHIAROLA NUOVA, 258
41042, FIORANO MODENESE
MODENA / ITALY
TEL +39 0536 1844200

LAMINAM S.P.A.
VIA VERDI, 5
20121, MILANO / ITALY
TEL +39 02 89092496



LAMINAM SERVICE S.r.l
VIA GHIAROLA NUOVA 258
41042, FIORANO MODENESE
MODENA / ITALY
T.+39 0536 1844200

LAMINAM | AUSTRALIA
SUPERIOR NATURAL SURFACES

infoaustralia@laminam.com

www.laminam.com

LAMINAM | JAPAN
SUPERIOR NATURAL SURFACES

info@laminam.jp

www.laminam.jp

LAMINAM | CANADA
SUPERIOR NATURAL SURFACES

info@laminamusa.com

www.laminamusa.com

LAMINAM | ISRAEL
SUPERIOR NATURAL SURFACES

office@laminam.co.il

www.laminam.co.il

LAMINAM | CHINA
SUPERIOR NATURAL SURFACES

info@laminamcn.com

ID WeChat: Laminam_Official

LAMINAM | UK
SUPERIOR NATURAL SURFACES

salesuk@laminam.com

www.laminam.com

LAMINAM | FRANCE
SUPERIOR NATURAL SURFACES

infofrance@laminam.com

www.laminam.com

LAMINAM | RUS
SUPERIOR NATURAL SURFACES

info@laminamrus.com

www.laminamrus.com

LAMINAM | GERMANY
SUPERIOR NATURAL SURFACES

infogermany@laminam.com

www.laminam.com

LAMINAM | USA
SUPERIOR NATURAL SURFACES

info@laminamusa.com

www.laminamusa.com

Certifications



Product certifications

UNI EN ISO 14021

Products containing at least 20% of pre-consumer re-cycled material in bulk (LEED 20) having an high solar reflectance index (SRI)

UNI EN ISO 14021

Products containing at least 30% of pre-consumer recycled material in bulk (LEED 30) having an high solar reflectance index (SRI)

UNI EN ISO 14021

Products containing at least 40% of pre-consumer recycled material in bulk (LEED 40) having an high solar reflectance index (SRI)

CCC



China Compulsory Certificate mark

KASHERUT



Laminam slabs used for counter to are certificated Kosher Parve

NSF



American Standard for food equipment "Ceramic Solid Surface For Food Zone"
Valid for the products featured on the certificate available on the website:
<https://www.laminam.com>

MED 96/98/EC e
2014/90/EU



Certification for use in the marine sector

MOCA



Laminam slabs are suitable for contact with food, in accordance with the MOCA Legislation (Material and Objects in Contact with Food Legislation)

Certifications



System certifications

UNI EN ISO 9001:



International Standard for Quality management systems

C-TPAT



Customs-Trade Partnership Against Terrorism - USA



Ceramics of Italy



We are
designers
of our own
spaces
seeking
uniqueness.